

Exova Warringtonfire
Holmesfield Road
Warrington
WA1 2DS
United Kingdom

T : +44 (0) 1925 655 116
F : +44 (0) 1925 655 419
E : warrington@exova.com
W: www.exova.com



Testing. Advising. Assuring.

Title:

The fire resistance performance of two single-acting, single-leaf doorsets incorporating various items of hardware tested in accordance with BS EN 1634-1:2014

Report No:

345074/A Issue 2



Prepared for:

Firestop Manufacturing Limited,
4 Wyvern Buildings,
Grove Trading Estate,
Dorchester,
Dorset,
DT1 1ST.

Date: 21st April 2016

Notified Body No:

0833



0249

This test report is additional to that issued as WF Test Report No. 345074 and dated 13th January 2015. The original test report remains valid and is not replaced by this additional test report.

Summary

Objective To determine the fire resistance performance of two single-acting, single-leaf timber based doorsets incorporating various items of hardware, mounted within a low density rigid supporting construction in accordance with BS EN 1634-1: 2014.

Test Sponsor **Firestop Manufacturing Limited,**
4 Wyvern Buildings, Grove Trading Estate, Dorchester, Dorset, DT1 1ST.

Summary of Tested Specimens For the purpose of the test the doorsets were referenced Doorset A and Doorset B.

Doorset A had overall nominal dimensions 2085 mm high by 1000 mm wide incorporating a door leaf with overall dimensions 2040 mm high by 932 mm wide by 44 mm thick. The door leaf was of a 3-layer particle board construction, with 8 mm hardwood lippings to the vertical edges and was hung within a softwood frame on three Eurospec ball bearing butt hinges referenced, HIN1242522P/11 BZP (item 5). The doorset incorporated the following hardware/accessories –

| Item Number | Item | Reference |
|-------------|--------------------------------|--------------|
| 1 | Concealed door closer | DCC2025CF/36 |
| 2 | Rim cylinder nightlatch | RCN8240M |
| 3 | 3 Star cylinder | CYM71270 |
| 4 | SS Security escutcheon | AEB1000SSS |
| 6 | Euro profile sashlock | ESS5030 |
| 7 | Serozzetta lever on round rose | SZC010SC |
| 8 | Sleeved letter plate | FS313 |
| 9 | Door viewer with glass lens | AA77 |
| 10 | Bolt through fix pull handle | PH500C |

Doorset B had overall nominal dimensions 2085 mm high by 1005 mm wide incorporating a door leaf with overall dimensions 2040 mm high by 932 mm wide by 54 mm thick. The door leaf was of a 3-layer particle board construction, with 8 mm hardwood lippings to the vertical edges and was hung within a hardwood frame on three Eurospec ball bearing butt hinges referenced, HIN14322P/11 BZP (item 11). The doorset incorporated the following hardware/accessories –

| Item Number | Item | Reference |
|-------------|---------------------------------------|---------------|
| 1 | Concealed door closer | DCC02025CF/36 |
| 2 | Rim cylinder nightlatch | RCN8440 |
| 3 | 3 Star cylinder | CYM71270 |
| 4 | SS Security escutcheon | AEB1000SSS |
| 12 | Din euro profile sashlock | DLS7260EP |
| 13 | Eliphtical twist lever on square rose | IT83020CP |
| 14 | Stainless steel door viewer | SWE1000 |
| 15 | Back to back pull handles | PCT11800BSS |
| 16 | Door knocker | SWE1020SSS |
| 17 | Door pull knob | SWE1062 |

The doorsets were installed so that they opened towards the heating conditions of the test and were un-latched for the purpose of the test.

| Test Results: | | Doorset A | Doorset B |
|------------------------------|-------------------|------------------|------------------|
| Integrity performance | Sustained flaming | 34 minutes | 46 minutes |
| | Gap gauge | 34 minutes | 60 minutes* |
| | Cotton Pad | 34 minutes | 46 minutes |

| | | | |
|-------------------------------|--|------------|------------|
| Insulation performance | | 34 minutes | 46 minutes |
|-------------------------------|--|------------|------------|

* The test duration. The test was discontinued after a period of 60 minutes.

Date of Test 28^h October 2014

This report may only be reproduced in full. Extracts or abridgements of reports shall not be published without permission of Exova Warringtonfire.

Signatories



Responsible Officer
D. Fitzsimmons*
Testing Officer



Approved
S. Gilfedder*
Certification Engineer



Head of Department
S. Hankey*
Operations Manager

* For and on behalf of **Exova Warringtonfire**.

Report Issued

Date: 21st April 2016

This copy has been produced from a .pdf format electronic file that has been provided by **Exova Warringtonfire** to the sponsor of the report and must only be reproduced in full. Extracts or abridgements of reports must not be published without permission of **Exova Warringtonfire**. The pdf copy supplied is the sole authentic version of this document. All pdf versions of this report bear authentic signatures of the responsible **Exova Warringtonfire** staff.

Issue 2 due to changes to reference numbers in schedule of components – D. Fitzsimmons – 20th April 2016

CONTENTS

PAGE NO.

| | |
|--|-----------|
| SUMMARY..... | 2 |
| SIGNATORIES | 4 |
| TEST PROCEDURE..... | 6 |
| TEST SPECIMEN | 7 |
| SCHEDULE OF COMPONENTS | 15 |
| DOORSET CLEARANCE GAPS | 21 |
| INSTRUMENTATION | 22 |
| TEST PHOTOGRAPHS..... | 25 |
| TEMPERATURE AND DEFLECTION DATA | 31 |
| PERFORMANCE CRITERIA AND TEST RESULTS | 44 |
| ONGOING IMPLICATIONS..... | 45 |
| CONCLUSIONS..... | 45 |

Test Procedure

Introduction

The doorsets are required to provide a fire separating function and were therefore tested in accordance with BS EN 1634-1: 2014 'Fire resistance tests for doors and shutter assemblies - Part 1: Fire doors and shutters'. This test report should be read in conjunction with that Standard and with BS EN 1363-1: 2012 'Fire resistance tests - Part 1: General requirements' and BS EN 1363-2: 1999, 'Fire resistance tests - Part 2: Alternative and additional procedures'.

The specimens were judged on their ability to comply with the performance criteria for integrity and insulation, as required by BS EN 1634-1: 2014.

The specific purpose of the test was to evaluate the effects of the inclusion of various items of building hardware into a previously tested doorset construction. Because of this, no direct field of application for the doorsets are included in this report.

Fire Test Study Group/EGOLF

Certain aspects of some fire test specifications are open to different interpretations. The Fire Test Study Group and EGOLF have identified a number of such areas and have agreed Resolutions which define common agreement of interpretations between fire test laboratories which are members of the Groups. Where such Resolutions are applicable to this test they have been followed.

Instruction To test

The test was conducted on the 28th October 2014 on behalf of **Firestop Manufacturing Limited**, the sponsor of the test.

Test Specimen Construction

A comprehensive description of the test construction is given in the Schedule of Components. The description is based on a detailed survey of the specimens and information supplied by the sponsor of the test.

The doorsets' storage, installation, and test preparation took place in the test laboratory between the 24th October 2014 and 28th October 2014

Installation

The doorsets incorporating the hardware were mounted within apertures provided within a high density rigid supporting construction. The doorsets were mounted such that they opened towards the heating conditions of the test.

Representatives of **Exova Warringtonfire** conducted the installation on the 26th October 2014.

Sampling

The concealed door closers for this test were sample selected by a representative of **Warrington Certification** on 11th August 2014.

Conditioning

The specimens' storage, construction, and test preparation took place in the test laboratory over a total, combined time of 4 days. Throughout this period of time both the temperature and the humidity of the laboratory were measured and recorded as being within a range of from 14°C to 19.5°C and 62.5% to 82% respectively.

Test Specimen

Figure 1- General elevation of test specimens and unexposed face thermocouples

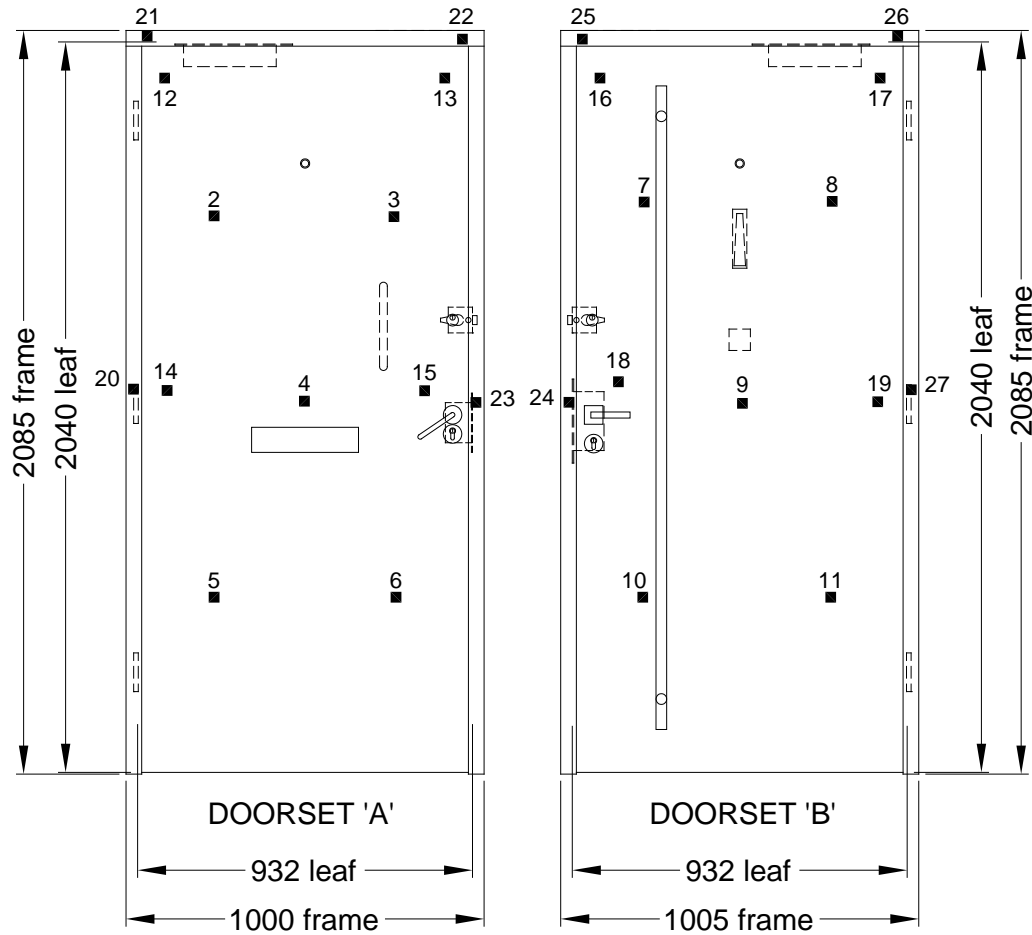

GENERAL ELEVATION
OF UNEXPOSED FACE

■ Positions of thermocouples

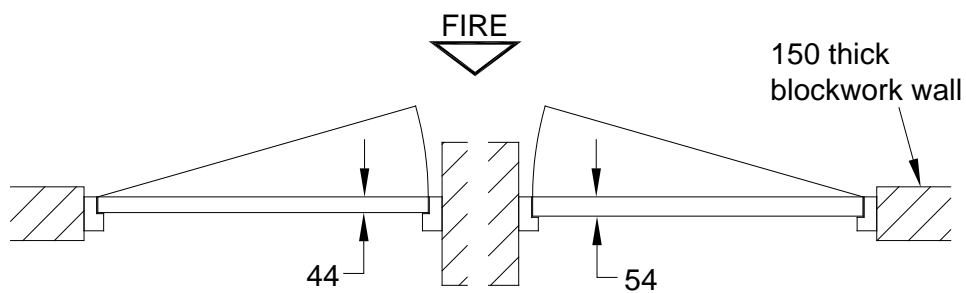

PLAN

Do not scale. All dimensions are in mm

Figure 2 – Elevation view of hardware to doorset 'A'

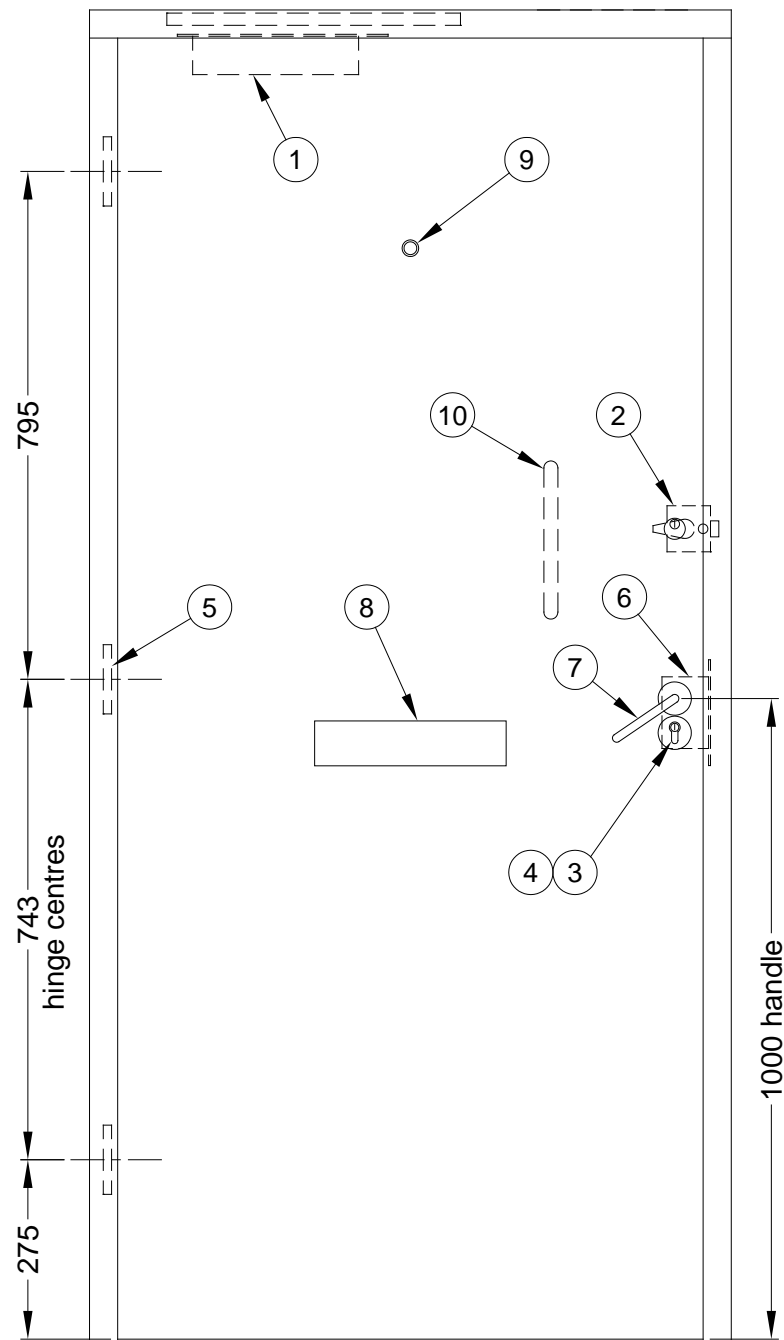

Do not scale. All dimensions are in mm

Figure 3 – Elevation view of hardware to doorset 'B'

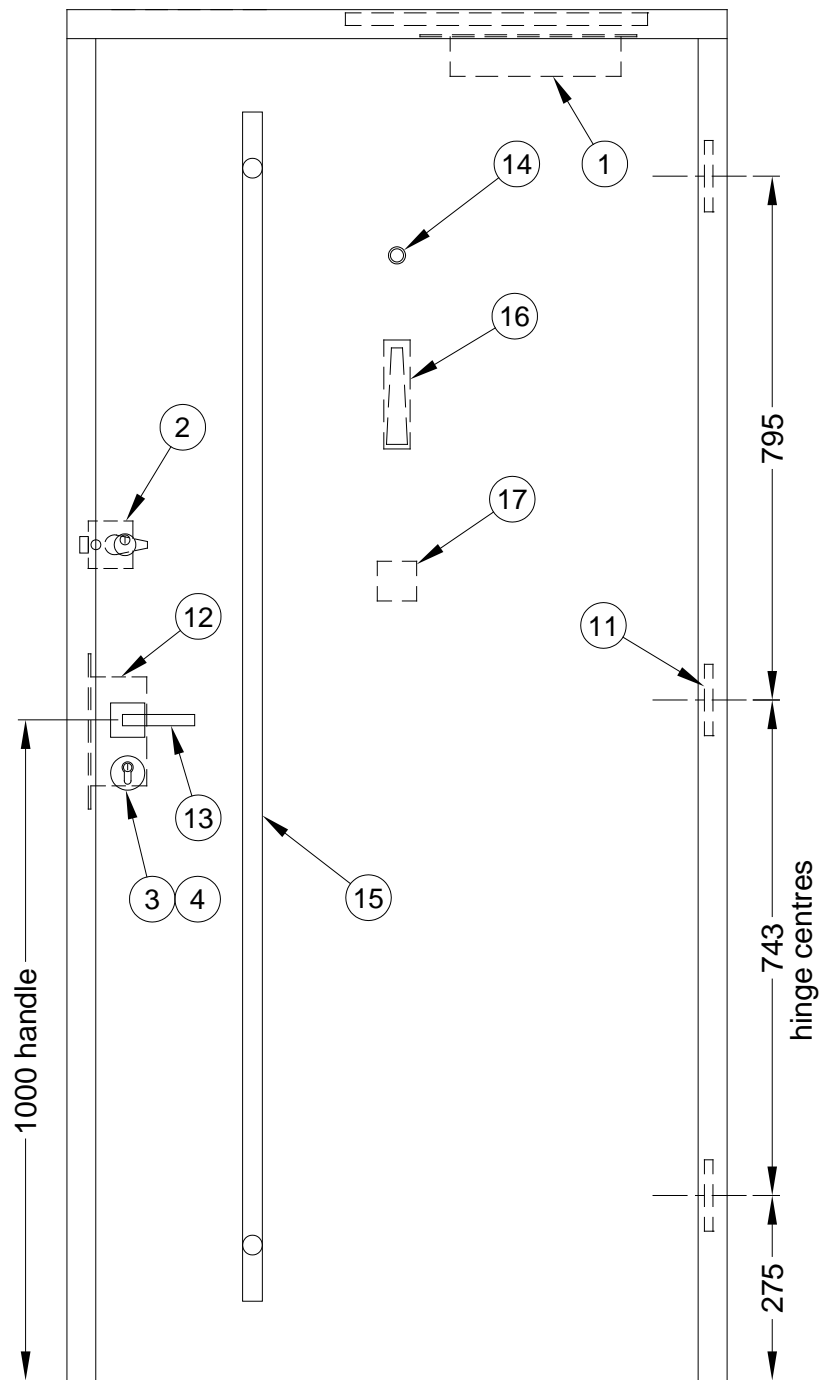

Do not scale. All dimensions are in mm

Figure 4 – Typical details of concealed door closer for both doorsets

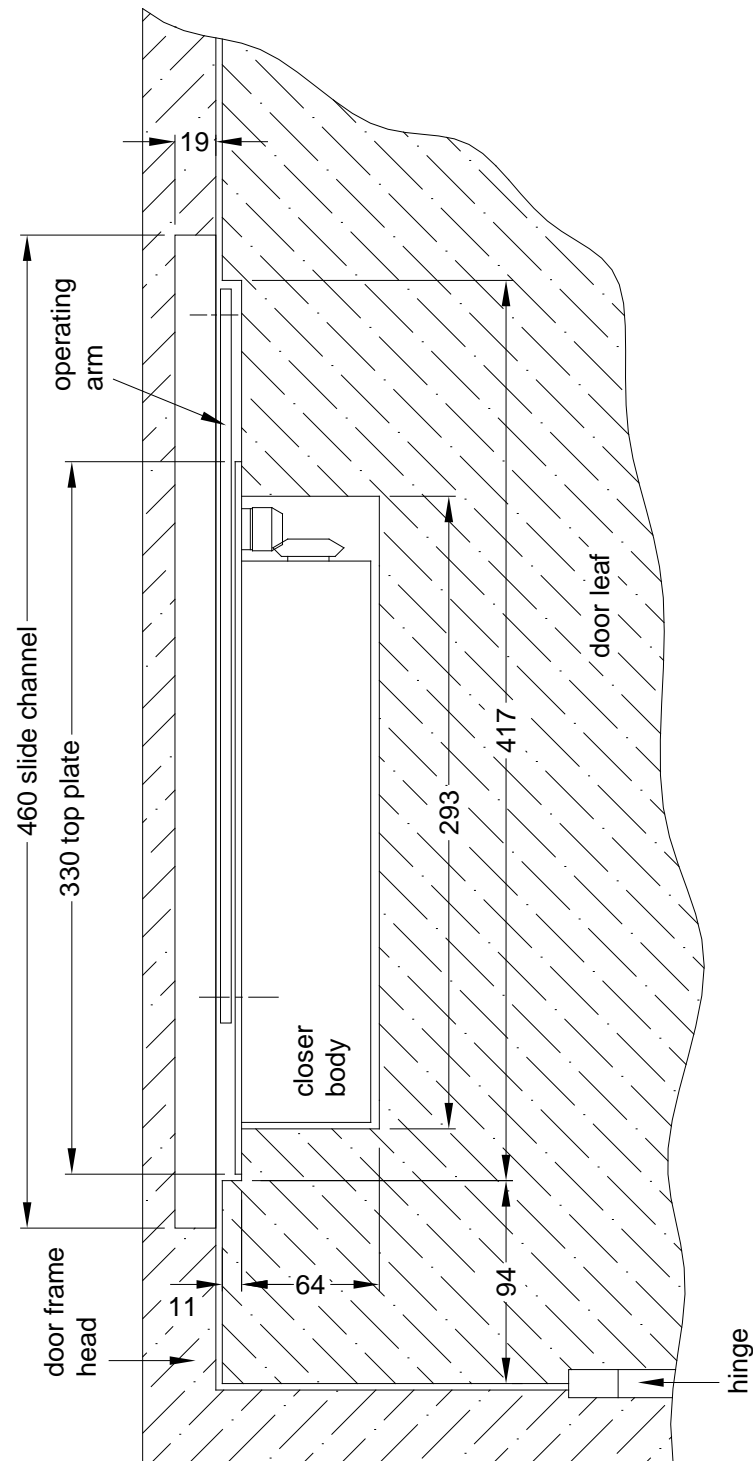

SECTIONAL ELEVATION OF CONCEALED DOOR CLOSER (ITEM 1)
TYPICAL FOR BOTH DOORSETS

Do not scale. All dimensions are in mm

Figure 5 – Details of hardware for doorset 'A'

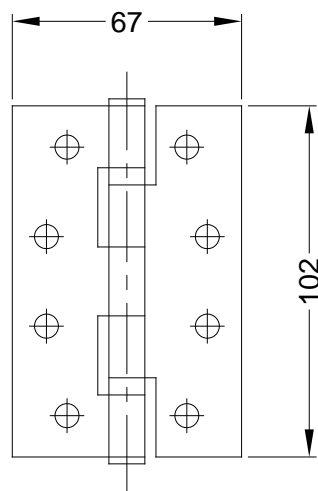
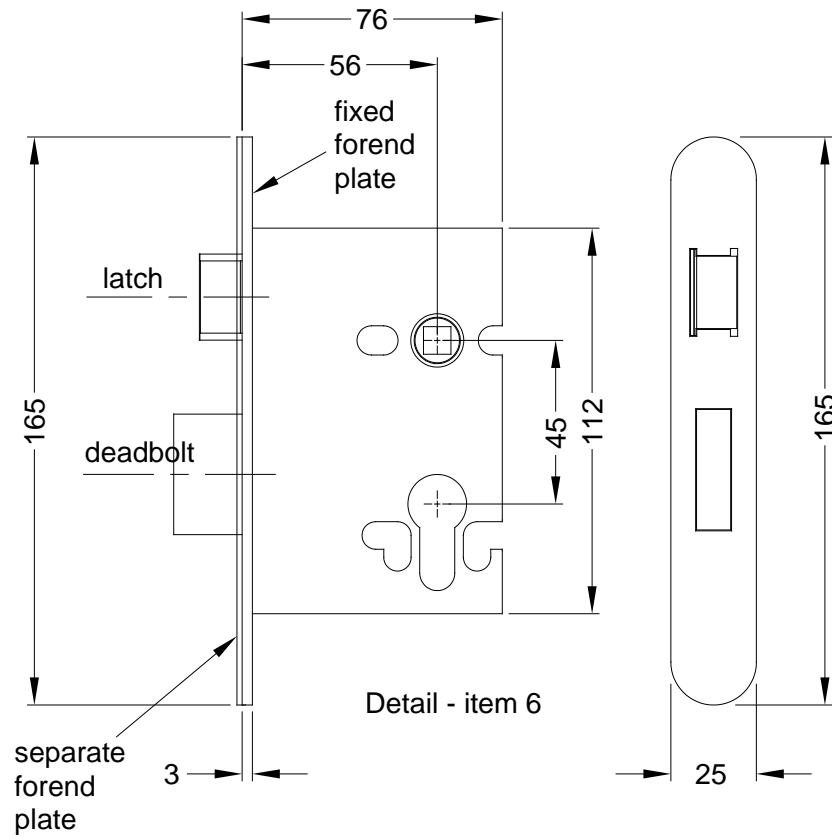

Detail - item 5

Do not scale. All dimensions are in mm

Figure 6 – Details of hardware for doorset 'B'

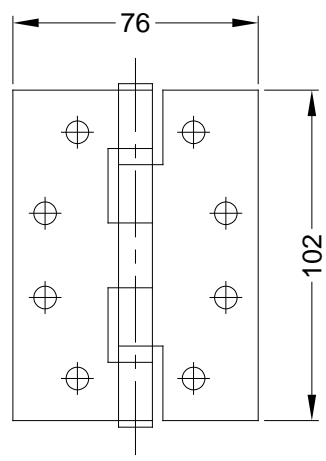
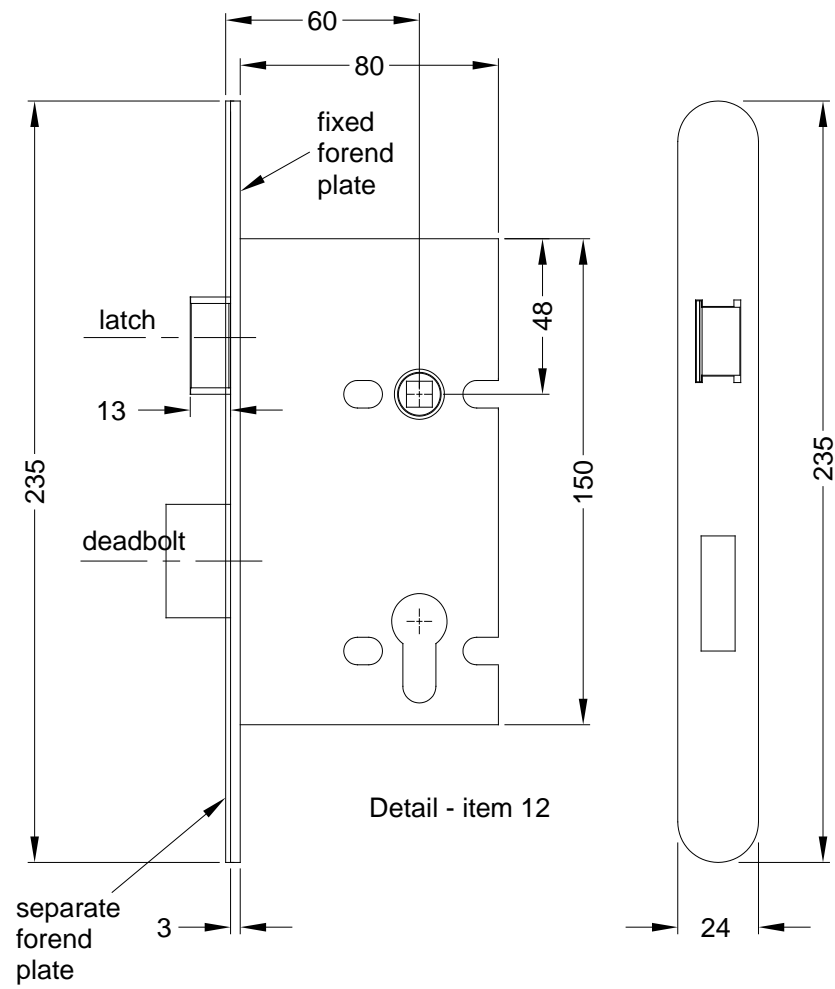

Detail - item 11

Do not scale. All dimensions are in mm

Figure 7 – Typical details of doorset 'A'

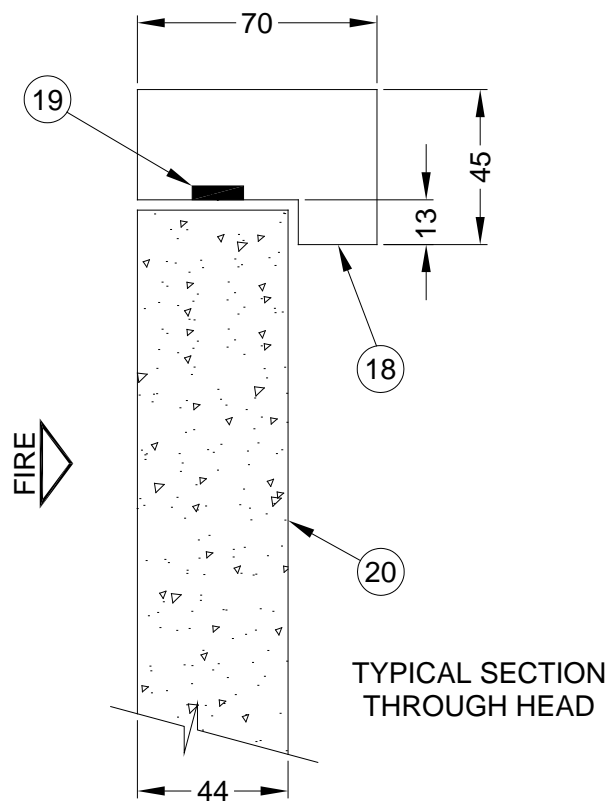
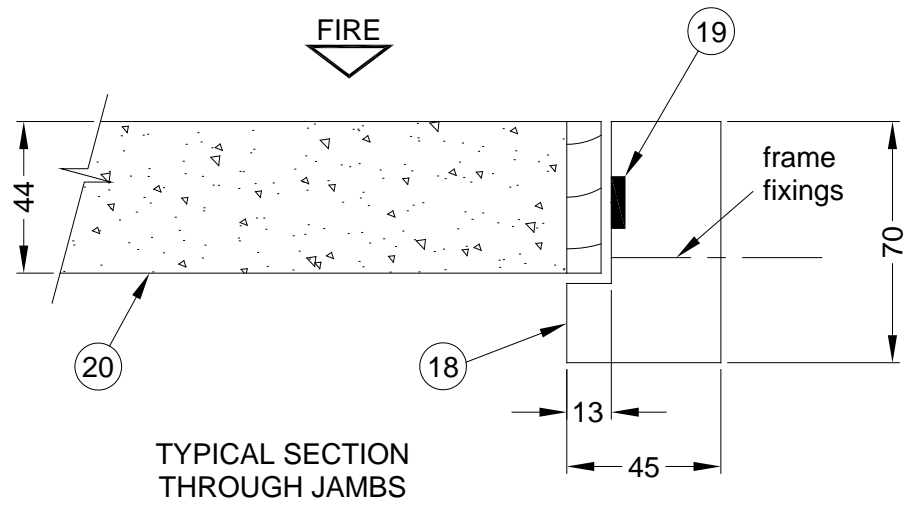

Do not scale. All dimensions are in mm

Figure 8 – Typical details of doorset 'B'

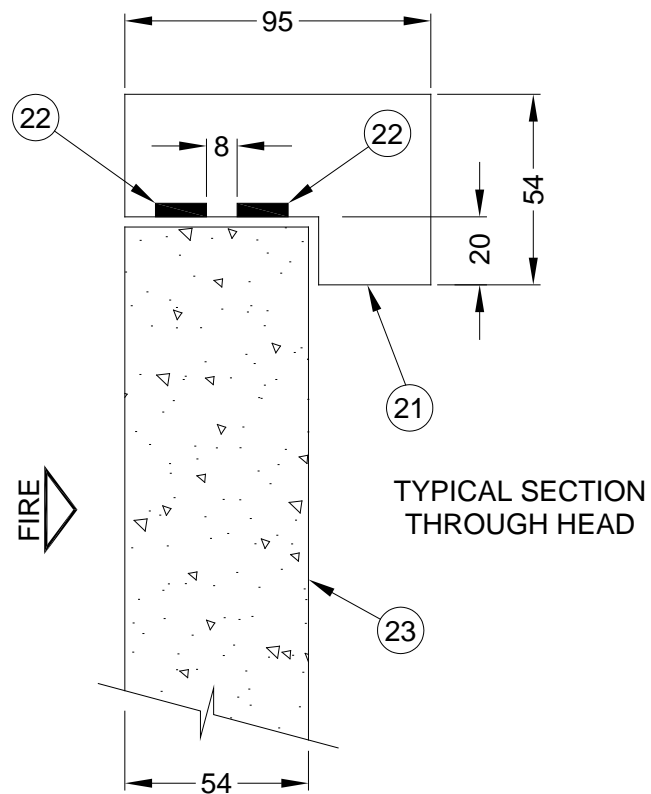
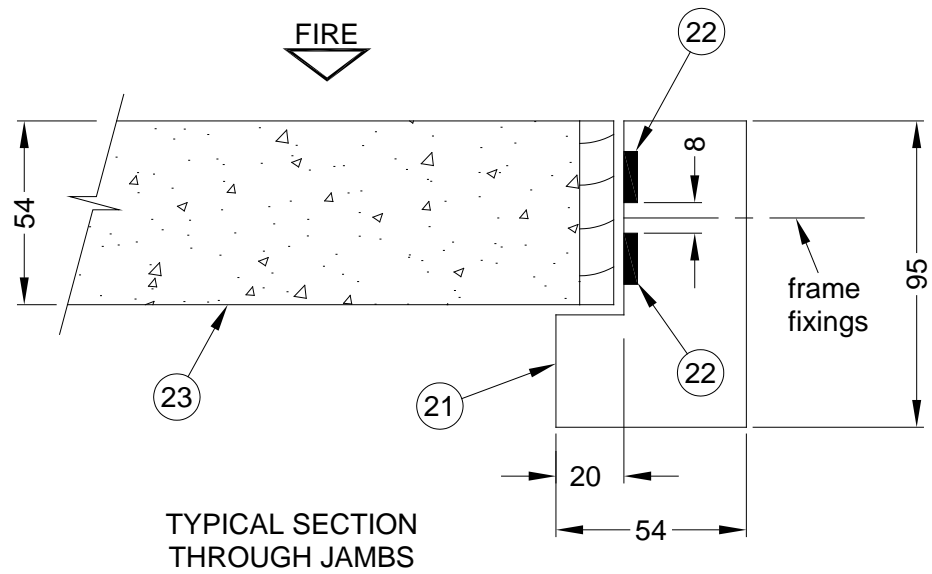

Do not scale. All dimensions are in mm

Schedule of Components

(Refer to Figures 1 to 8)
(All values are nominal unless stated otherwise)
(All other details are as stated by the sponsor)

| <u>Item</u> | <u>Description</u> |
|--|--|
| Details of Hardware fitted to both doorsets (items 1 to 4) | |
| 1. Overhead concealed door closer | |
| Manufacturer | : Eurospec Architectural Hardware |
| Type | : Size 2-5 concealed door closer |
| Reference | : DCC2025CF/36 |
| Material | |
| i. closer body | : Aluminium |
| ii. slide channel | : Aluminium |
| iii. operating arm | : Steel |
| iv. slider | : Nylon |
| v. slide channel end caps | : Nylon |
| Location | : Closer body fitted within mortise in top edge of door leaf. Slide channel fitted within mortise in the door frame head. See Figure 4. |
| Fixing method | : 4.8 mm diameter steel woodscrews, 50 mm long for closer body and 25 mm long for slide channel. |
| Details of Intumescent bedding material | |
| i. manufacturer | : Firestop Manufacturing Limited |
| ii. manufacturers product reference | : FS1275/FS1276 |
| iii. material | : Intercalated graphite |
| iv. thickness | : 0.8 mm |
| Fixing method | : Self adhesive |
| v. location | : Mortise within the door leaf for closer body was lined with single layer. Mortise within the door frame head for slide channel was lined with single layer, except for each end of the channel which is fitted with 3 no. layers. Also, single layer fitted over top plate of the closer body. |
| Maximum closing moments (measured by Exova Warringtonfire) | |
| i. doorset 'A' | : 17 Newton metres (Nm) |
| ii. doorset 'B' | : 17 Nm |
| Maximum opening moments (measured by Exova Warringtonfire) | |
| i. doorset 'A' | : 30 Nm |
| ii. doorset 'B' | : 30 Nm |
| 2. Door latch | |
| Manufacturer | : Eurospec Architectural Hardware |
| Type | : Rim cylinder night-latch 40mm backset |
| Reference | : RCN8440 |
| Material | |
| i. lock case | : Zinc die cast |
| ii. latch bolt | : Zinc die cast |
| iii. strike plate | : Zinc die cast |
| iv. mounting plate | : Steel |
| v. rim cylinder | : Brass |
| Operation of latch bolt | : Disengaged |

Item

Description

2. Door latch - continued

Details of Intumescent liner

| | | |
|-----------------|---|--------------------------------|
| i. manufacturer | : | Firestop Manufacturing Limited |
| ii. reference | : | FS318 |
| iii. material | : | Intercalated graphite |
| iv. thickness | : | 0.8 mm |
| v. location | : | Lined the hole for cylinder |

3. Cylinder

| | | |
|--------------|---|---------------------------------|
| Manufacturer | : | Eurospec Architectural Hardware |
| Type | : | 3 star cylinder 70mm |
| Reference | : | CYM71270 |
| Material | : | Brass |

4. Escutcheon

| | | |
|--------------|---|---------------------------------|
| Manufacturer | : | Eurospec Architectural Hardware |
| Type | : | Security escutcheon |
| Reference | : | AEB1000SSS |
| Material | : | Stainless steel |

Details of Hardware fitted to doorset 'A' only (items 5 to 10)

5. Hinges

| | | |
|---------------|---|--|
| Manufacturer | : | Eurospec Architectural Hardware |
| Type | : | Ball bearing butt hinge Grade 11 |
| Reference | : | HIN142522P/11 BZP |
| Material | : | Mild steel |
| Overall size | : | 102 mm x 67 mm x 2 mm thick blades |
| Quantity | : | 3 no. hinges |
| Fixing method | : | 4 no. countersunk head steel woodscrews per blade, 30 mm long x 4.9 mm diameter. |

Details of Intumescent bedding material

| | | |
|-----------------|---|--|
| i. manufacturer | : | Firestop Manufacturing Limited |
| ii. reference | : | FS501 |
| iii. material | : | Intercalated graphite |
| iv. thickness | : | 0.8 mm |
| Fixing method | : | Self adhesive fixed beneath all hinge blades |

6. Door lock

| | | |
|---------------------------|---|--|
| Manufacturer | : | Eurospec Architectural Hardware |
| Type | : | Euro profile mortice sashlock 76mm |
| Reference | : | ESS5030 |
| Material | : | |
| i. lock case | : | Steel |
| ii. separate forend plate | : | Stainless steel |
| iii. strike plate | : | Stainless steel |
| iv. latch bolt | : | Brass |
| v. dead bolt | : | Brass |
| Overall sizes | : | |
| i. lock case | : | 73 mm deep x 112 mm high |
| ii. forend plate | : | 165 mm long x 25 mm wide |
| iii. strike plate | : | 180 mm long x 30 mm wide |
| Fixing method | : | Steel screws, 30 mm long x 4 mm diameter |
| Operation of latch bolt | : | Disengaged |
| Operation of dead bolt | : | Disengaged |

| <u>Item</u> | <u>Description</u> |
|---|--|
| 6. Door lock - continued | |
| Details of Intumescent bedding material | |
| i. manufacturer | : Firestop Manufacturing Limited |
| ii. reference | : FS1271 |
| iii. material | : Intercalated graphite |
| iv. thickness | : 0.8 mm |
| v. location | : Fitted to all faces and edges of casing and behind forend plate. Also fitted beneath the strike plate. |
| 7. Lever handleset | |
| Manufacturer | : Carlisle Brass |
| Type | : Serozzetta lever on round rose |
| Reference | : SZC010SC |
| Material | |
| i. lever handles and rose covers | : Zinc diecast |
| ii. inner roses | : Plastic |
| 8. Letter plate | |
| Manufacturer | : Firestop Manufacturing Limited |
| Type | : Sleeved letter plate c/w intumescent liner |
| Reference | : FS313 |
| Material | : Stainless steel flaps, plastic body |
| Aperture clear opening size | : 38 mm high x 250 mm wide |
| Fixing method | : Through bolts and woodscrews (as supplied with kit) |
| Details of Intumescent liner | |
| i. manufacturer | : Firestop Manufacturing Limited |
| ii. reference | : FS1268 |
| iii. material | : Intercalated graphite |
| iv. thickness | : 2 no. layers, each approx 2 mm thick x 57 mm wide |
| v. location | : Self adhesive fixed around outer face of sleeve that fits within door leaf. |
| 9. Door viewer | |
| Manufacturer | : Carlisle Brass |
| Reference | : AA77 |
| Material | : Glass lens with brass body |
| Details of Intumescent liner | |
| i. manufacturer | : Firestop Manufacturing Limited |
| ii. reference | : FS318 |
| iii. material | : Intercalated graphite |
| iv. thickness | : 0.8 mm |
| v. location | : Lined the hole in door leaf for door viewer |
| 10. Pull handle | |
| Manufacturer | : Eurospec Architectural Hardware |
| Type | : Bolt through fix pull handle |
| Reference | : PH500C 225mm |
| Material | : Stainless steel (straight section) and Zinc (return sections) |
| Size | : 22 mm diameter x 225 mm centres |
| Location | : Fitted at exposed face of the door leaf |

| <u>Item</u> | <u>Description</u> |
|--|--|
| Details of Hardware fitted to doorset 'B' only (items 11 to 17) | |
| 11. Hinges | |
| Manufacturer | : Eurospec Architectural Hardware |
| Type | : Ball bearing butt hinge Grade 11 |
| Reference | : HIN14322P/11 BZP |
| Material | : Mild steel |
| Overall size | : 102 mm x 76 mm x 2 mm thick blades |
| Quantity | : 3 no. hinges |
| Fixing method | : 4 no. countersunk head steel woodscrews per blade, 30 mm long x 4.9 mm diameter. |
| Details of Intumescent bedding material | |
| i. manufacturer | : Firestop Manufacturing Limited |
| ii. reference | : FS501 |
| iii. material | : Intercalated graphite |
| iv. thickness | : 0.8 mm |
| Fixing method | : Self adhesive fixed beneath all hinge blades |
| 12. Door lock | |
| Manufacturer | : Eurospec Architectural Hardware |
| Type | : DIN euro profile mortice sashlock, 60mm backset |
| Reference | : DLS7260EP |
| Material | |
| i. lock case | : Steel |
| ii. separate forend plate | : Stainless steel |
| iii. strike plate | : Stainless steel |
| iv. latch bolt | : Stainless steel |
| v. dead bolt | : Stainless steel |
| Overall sizes | |
| i. lock case | : 80 mm deep x 150 mm high |
| ii. forend plate | : 235 mm long x 24 mm wide |
| iii. strike plate | : 175 mm long x 22 mm wide |
| Fixing method | : Steel screws, 30 mm long x 4 mm diameter |
| Operation of latch bolt | : Disengaged |
| Operation of dead bolt | : Disengaged |
| Details of Intumescent bedding material | |
| i. manufacturer | : Firestop Manufacturing Limited |
| ii. reference | : FS1257 |
| iii. material | : Intercalated graphite |
| iv. thickness | : 0.8 mm |
| v. location | : Fitted to all faces and edges of casing and behind forend plate. Also fitted beneath the strike plate. |
| 13. Lever handleset | |
| Manufacturer | : Carlisle Brass |
| Type | : Elliptical twist lever on square rose |
| Reference | : IT83020CP |
| Material | |
| i. lever handles and rose covers | : Zinc diecast |
| ii. inner roses | : Zinc diecast |
| 14. Door viewer | |
| Manufacturer | : Eurospec Architectural Hardware |
| Reference | : SWE1000 |
| Material | : Glass lens with stainless steel body |

| <u>Item</u> | <u>Description</u> |
|---|---|
| 15. Pull handles | |
| Manufacturer | : Eurospec Architectural Hardware |
| Type | : Back to back fix pull handles |
| Reference | : PCT11800BSS |
| Material | : Stainless steel |
| Size | : 30 mm diameter x 1630 mm centres |
| Fixing method | : Back to back fixing kit, as supplied with pull handles. |
| Details of fixing kit | |
| Reference | : BBF1025SSS |
| Material | : M8 threaded bolt is steel. Roses are zinc diecast with a stainless steel lining. |
| Details of Intumescent liner | |
| i. manufacturer | : Firestop Manufacturing Limited |
| ii. reference | : FS318 |
| iii. material | : Intercalated graphite |
| iv. thickness | : 0.8 mm |
| v. location | : Fitted around the M8 bolts |
| 16. Door knocker | |
| Manufacturer | : Eurospec Architectural Hardware |
| Reference | : SWE1020SSS |
| Material | : Stainless steel |
| Overall size | : 166 mm x 40 mm back plate |
| Fixing method | : Through bolted to exposed face of door leaf using 2 no. M4 steel bolts. |
| 17. Door pull knob | |
| Manufacturer | : Eurospec Architectural Hardware |
| Reference | : SWE1062 |
| Material | : Stainless steel/steel |
| Overall size | : 62 mm x 62 mm square knob |
| Fixing method | : Through bolted to exposed face of door leaf using single M8 steel bolt. |
| Timber Doorset 'A' (supplied by Exova Warringtonfire) consisting of items 18 to 20 | |
| 18. Door frame jambs and head | |
| Material | : Timber, softwood |
| Nominal Density | : 510 kg/m ³ |
| Overall section size | : 45 mm x 70 mm, with a 13 mm deep x 44 mm wide rebate. |
| Jambs to head jointing method | : Butt joint with 2 no. steel screws |
| Fixing method to masonry surround | |
| i. type | : Countersunk head steel screws into plastic plugs through jambs. |
| ii. size | : 100 mm long x 5.6 mm (No.12) diameter screws |
| iii. quantity | : 4 no. screws along full height of closing jamb. 6 no. screws along hinged jamb (2 no. screws at 180 mm centres about each hinge position). |
| 19. Door frame intumescent seal | |
| Manufacturer | : Firestop Manufacturing Limited |
| Reference | : FS116 |
| Material | : Graphite based intumescent within a polyvinyl chloride (PVC) carrier. |
| Overall section size | : 15 mm wide x 4 mm deep carrier |

| <u>Item</u> | <u>Description</u> |
|---|---|
| 19. Door frame intumescent seal - continued | |
| Fixing method | : Single seal self-adhesive fixed within a groove along the rebate of the door frame jambs and head. The seal was trimmed back to 4 mm wide at the hinges and back to 8 mm wide at the night latch strike plate, and also interrupted at the door lock strike plate. |
| 20. Door leaf | |
| Manufacturer | : Halspan |
| Reference | : 'Optima' door blank |
| Material | : 3-layer particle board. Door blank fitted with 8 mm thick Sapele hardwood lipping along the vertical edges by Exova Warringtonfire using formaldehyde adhesive. |
| Thickness | : 44 mm |
| Timber Doorset 'B' (supplied by Exova Warringtonfire) consisting of items 21 to 23 | |
| 21. Door frame jambs and head | |
| Material | : Hardwood, species Sapele |
| Overall section size | : 54 mm x 95 mm, with a 20 mm deep x 55 mm wide rebate. |
| Jambs to head jointing method | : Mortise & tenon with 2 no. steel screws |
| Fixing method to masonry surround | |
| i. type | : Countersunk head steel screws into plastic plugs through jambs. |
| ii. size | : 100 mm long x 5.6 mm (No.12) diameter screws |
| iii. quantity | : 4 no. screws along full height of closing jamb. 6 no. screws along hinged jamb (2 no. screws at 180 mm centres about each hinge position). |
| 22. Door frame intumescent seal | |
| Manufacturer | : Firestop Manufacturing Limited |
| Reference | FS116 |
| Material | : Graphite based intumescent within a polyvinyl chloride (PVC) carrier. |
| Overall section size | : 15 mm wide x 4 mm deep carrier |
| Fixing method | : 2 no. seals self-adhesive fixed within grooves 8 mm apart along the rebate of the door frame jambs and head. The outer seal was interrupted at the hinges, door lock strike plate and night latch strike plate. The inner seal was continuous at the hinges and at night latch, and was notched around the door lock strike plate. Both seals were trimmed back around the door closer slide channel. |
| 23. Door leaf | |
| Manufacturer | : Halspan |
| Reference | : 'Prima' door blank |
| Material | : 3-layer particle board. Door blank fitted with 8 mm thick Sapele hardwood lipping along the vertical edges by Exova Warringtonfire using formaldehyde adhesive. |
| Thickness | : 54 mm |

Doorset Clearance Gaps

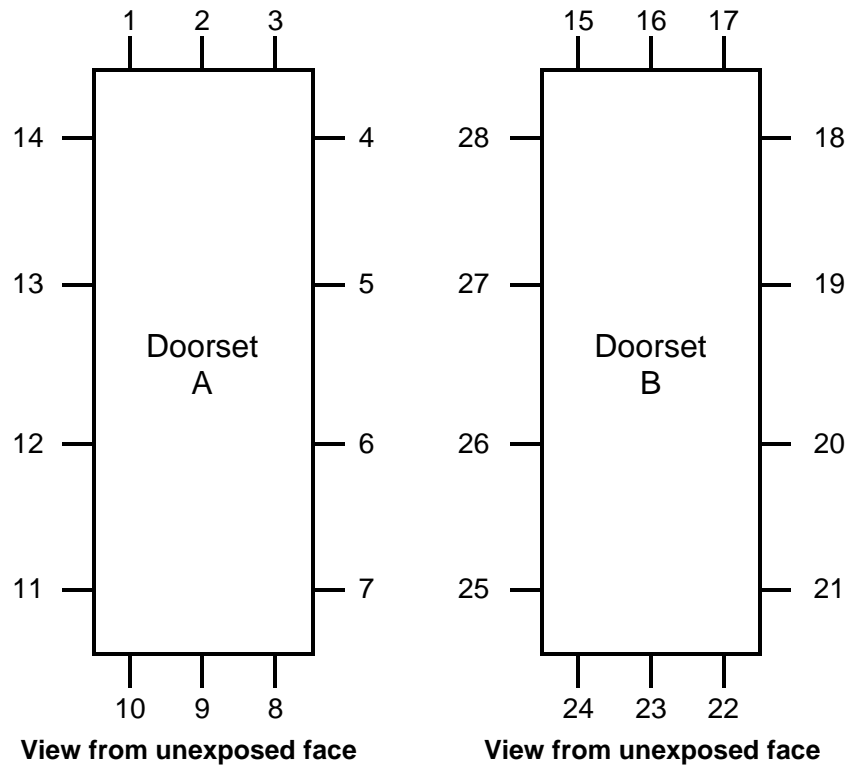

| Door Ref | Gap Dimension in mm at Positions | | | | | | | | | | | | | |
|----------|----------------------------------|-----|-----|-----|---------|-----|-----|------|------|---------|-----|-----|-----|-----|
| | 1 | 2 | 3 | 4 | 5 | 6 | 7 | 8* | 9* | 10* | 11 | 12 | 13 | 14 |
| A | 2.4 | 3.5 | 4.0 | 2.7 | 2.8 | 2.8 | 2.2 | 10.5 | 9.7 | 9.3 | 2.4 | 0.1 | 1.6 | 1.9 |
| | 15 | 16 | 17 | 18 | 19 | 20 | 21 | 22* | 23* | 24* | 25 | 26 | 27 | 28 |
| B | 2.9 | 2.1 | 2.1 | 1.7 | 0.4 | 1.0 | 0.3 | 9.9 | 10.1 | 10.1 | 4.1 | 3.5 | 3.8 | 3.2 |
| | Mean | | 2.4 | | Maximum | | | 4.0 | | Minimum | | | 2.2 | |
| B | Mean | | 2.2 | | Maximum | | | 4.1 | | Minimum | | | 0.3 | |

| Door Ref | Gap Between Face of Leaf and Doorstop in mm at Position | | | | | | | | | | | | | |
|----------|---|-----|-----|-----|-----|-----|-----|-----|-----|-----|-----|-----|-----|-----|
| | 1 | 2 | 3 | 4 | 5 | 6 | 7 | 8* | 9* | 10* | 11 | 12 | 13 | 14 |
| A | 0.3 | 4.0 | 4.0 | 2.2 | 0.9 | 0.3 | 0.3 | # | # | # | 1.7 | 2.1 | 1.7 | 1.4 |
| | 15 | 16 | 17 | 18 | 19 | 20 | 21 | 22* | 23* | 24* | 25 | 26 | 27 | 28 |
| B | 2.9 | 2.1 | 1.7 | 0.4 | 1.0 | 0.3 | 0.8 | # | # | # | 3.1 | 3.7 | 3.7 | 2.2 |

* Dimension not included in calculations

Dimension not measured

ALL DIMENSIONS ARE IN mm

Instrumentation

| | |
|--|---|
| General | The instrumentation was provided in accordance with the requirements of the Standard. |
| Furnace | The furnace was controlled so that its mean temperature complied with the requirements of BS EN 1363-1: 2012 Clause 5.1 using six plate thermometers, distributed over a plane 100 mm from the surface of the test construction. |
| General | Thermocouples were provided to monitor the unexposed surface of the specimens and the output of all instrumentation was recorded at no less than one minute intervals as follows: |
| Thermocouples 2 to 6 (Doorset A) & Thermocouples 7 to 11 (Doorset B) | At five positions on each doorset, one approximately at the centre and one at the approximate centre of each quarter section of the doorset. |
| Thermocouples 12 to 15 (Doorset A) & Thermocouples 16 to 19 (Doorset B) | At four positions on each door leaf, positioned at 100 mm in from the door leaf vertical edges, two at mid-height, and two at 100 mm below the top edge of the leaf. |
| Thermocouples 20 to 23 (Doorset A) & Thermocouples 24 to 27 (Doorset B) | At four positions on the unexposed face of each door frame, at two positions on the top horizontal frame member, one positioned approximately 50 mm from each vertical edge and one on each vertical member, positioned at mid height. The locations and reference numbers of the various unexposed surface thermocouples are shown in Figure 1. |
| Roving Thermocouple | A roving thermocouple was available to measure temperatures on the unexposed surface of the specimens at any position which might appear to be hotter than the temperatures indicated by the fixed thermocouples. |
| Integrity Criteria | Cotton pads and gap gauges were available to evaluate the integrity of the specimens. |
| Furnace Pressure | The furnace atmospheric pressure was controlled so that it complied with the requirements of BS EN 1363-1: 1999. Clause 5.2. The calculated pressure differential relative to the laboratory atmosphere at the top of each doorset was 14 (± 3) Pa. |

Test Observations

| Time | | All observations are from the unexposed face unless noted otherwise. |
|------|------|---|
| mins | secs | |
| 00 | 00 | The test commences. |
| 0 | 58 | Light steam/smoke release from the head and sides of both doorsets. |
| 2 | 00 | Steam/smoke release increases from the sides and head of both leaves. |
| 4 | 00 | Steam/smoke release can now be seen from the letter box on leaf A. |
| 5 | 56 | Slight discolouring of the leaf at the head of leaf A at mid-width. |
| 7 | 45 | Steam/smoke release continue at the heads of both leaves but has now decreased everywhere else. |
| 9 | 15 | Smoke release now mid-height around lock set leaf B. When viewed from the exposed face the handle letterbox have melted away on leaf A and the handle on leaf B. |
| 13 | 00 | Steam/smoke release can now be seen around the lockset on leaf B. |
| 14 | 19 | Smoke release at head of leaf A has now decreased apart from at the top corner of the hinge edge. |
| 17 | 40 | Very light smoke release can be seen around the hinges of leaf A discolouring can now be seen. |
| 19 | 00 | Heavy smoke release continuing at the top corner at the hinged edge of leaf A and along the enter head of leaf B. |
| 21 | 40 | Very light smoke release from around the spy hole and leaf A. |
| 24 | 20 | The top corner of the leading edge of leaf A has started releasing smoke as the above frame starts to discolour. |
| 28 | 30 | Discolouring at the centre of the head of leaf A is now evident as smoke release from this area increases. |
| 30 | 00 | Screw fixings for pull handle and around handle and letter box on leaf A have now started lightly releasing smoke. |
| 32 | 00 | Smoke releases form the top corner of hinged edge of leaf A increases. |
| 33 | 00 | Discoloured area next to the concealed closer in the centre of the head of leaf A is now showing signs of glowing; cotton wool pad integrity test over the glowing, pad didn't discolour or ignite. |
| 34 | 39 | Sustained flame at head of doorset A , Leaf A is now blanked off to allow test to continue on leaf B. |

Time

mins secs

- 38 00** Smoke release from lockset of leaf B increase a light smoke release can be seen from the door viewer.
- 42 00** Smoke release through cylinder hole continues to increase.
- 44 00** Centre of the head of leaf B is now glowing.
- 46 00** **Sustained flame at the head of leaf B around the concealed closer, area blanked of with super wool to allow test to continue on the rest of the leaf.**
- 48 00** Smoke release from top corners of leading edge and around lockset increases.
- 55 00** Smoke release continues to increase from top corner of the leading edge as well as around the lock as the top and bottom spy holes continue to discolour and lightly release smoke.
- 57 00** **Sustained flame around top hinge area blanked off to allow test to continue.**
- 58 00** Glowing gap can now be seen of top corner of leading edge.
- 59 40** **Sustained flame at the head at top corner of leading edge.**
- 60 60** **Test stopped at client's request.**

Post-test comment

Doorset A - All of the hardware on Doorset "A" had achieved in excess of 30 minutes without causing integrity failure.

Doorset B - Apart from the item of hardware referenced 'DCC2025CF/36', the hardware was not responsible for the integrity failure of the doorset, All other remaining hardware on Doorset "B" achieved in excess of 50 minutes without causing integrity failure

Test Photographs

The exposed face of the doorsets prior to testing



The unexposed face of the doorsets prior to testing



The unexposed face of the doorsets after 10 minutes of testing



The unexposed face of the doorsets after 20 minutes of testing



The unexposed face of the doorsets after 30 minutes of testing



The unexposed face of the doorsets after 34 minutes of testing as sustained flaming formed at the head of Doorset A



The unexposed face of the doorsets after 40 minutes of testing

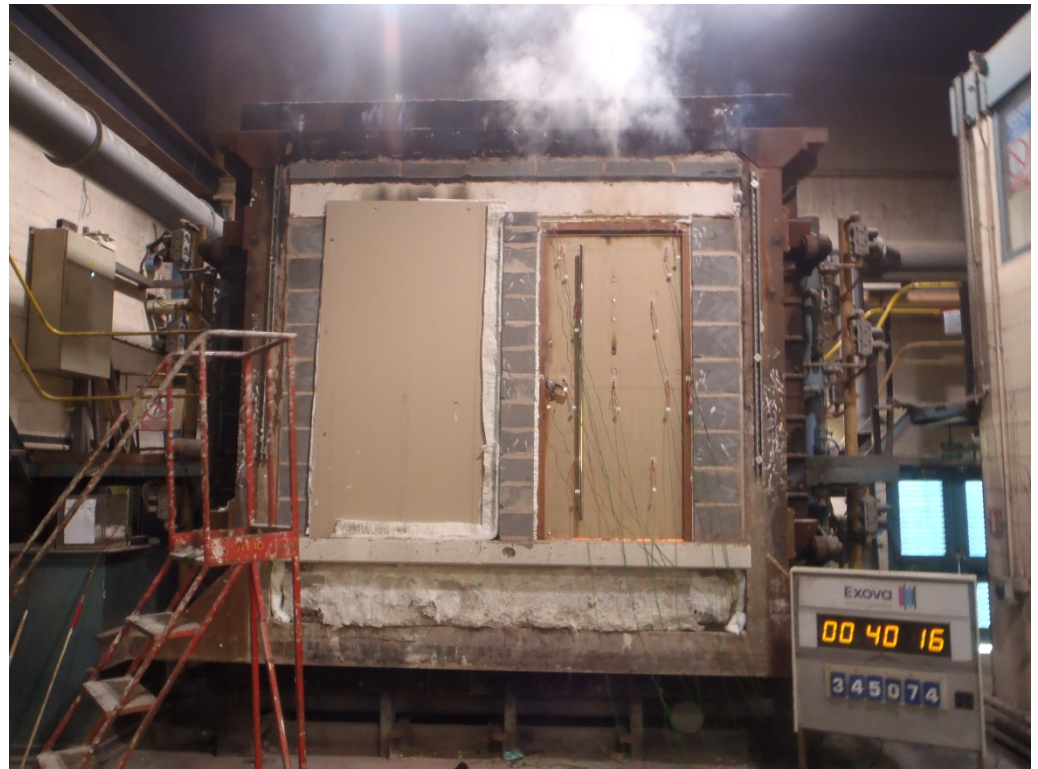

The unexposed face of the doorsets after 46 minutes of testing as sustained flaming formed at the head of Doorset B



The unexposed face of the doorsets after 55 minutes of testing



The unexposed face of the doorsets after 60 minutes of testing after which time the test was discontinued



The exposed face
of the test
construction
immediately after
the test



Temperature and Deflection Data

Mean furnace temperature, together with the temperature/time relationship specified in the Standard

| Time Mins | Specified Furnace Temperature Deg. C | Actual Furnace Temperature Deg. C |
|--------------|---|--|
| 0 | 20 | 23 |
| 2 | 445 | 463 |
| 4 | 544 | 683 |
| 6 | 603 | 682 |
| 8 | 646 | 633 |
| 10 | 678 | 658 |
| 12 | 706 | 715 |
| 14 | 728 | 711 |
| 16 | 748 | 752 |
| 18 | 766 | 727 |
| 20 | 781 | 756 |
| 22 | 796 | 812 |
| 24 | 809 | 817 |
| 26 | 820 | 814 |
| 28 | 832 | 838 |
| 30 | 842 | 852 |
| 32 | 852 | 833 |
| 34 | 860 | 856 |
| 36 | 869 | 868 |
| 38 | 877 | 879 |
| 40 | 885 | 881 |
| 42 | 892 | 887 |
| 44 | 899 | 894 |
| 46 | 906 | 899 |
| 48 | 912 | 901 |
| 50 | 918 | 928 |
| 52 | 924 | 916 |
| 54 | 930 | 926 |
| 56 | 935 | 942 |
| 58 | 940 | 947 |
| 60 | 945 | 982 |

Individual and mean temperatures recorded on the unexposed surface of Doorset A

| Time Mins | T/C Number 2 Deg. C | T/C Number 3 Deg. C | T/C Number 4 Deg. C | T/C Number 5 Deg. C | T/C Number 6 Deg. C | Mean Temp Deg. C |
|--------------|------------------------------|------------------------------|------------------------------|------------------------------|------------------------------|------------------------|
| 0 | 17 | 17 | 17 | 17 | 18 | 17 |
| 1 | 17 | 17 | 17 | 17 | 18 | 17 |
| 2 | 17 | 17 | 17 | 17 | 18 | 17 |
| 3 | 17 | 17 | 17 | 17 | 18 | 17 |
| 4 | 17 | 17 | 17 | 17 | 18 | 17 |
| 5 | 17 | 17 | 18 | 18 | 18 | 18 |
| 6 | 17 | 18 | 18 | 18 | 18 | 18 |
| 7 | 17 | 18 | 19 | 18 | 18 | 18 |
| 8 | 18 | 18 | 20 | 18 | 18 | 18 |
| 9 | 18 | 18 | 28 | 18 | 18 | 20 |
| 10 | 19 | 19 | 37 | 19 | 19 | 23 |
| 11 | 20 | 20 | 39 | 20 | 20 | 24 |
| 12 | 21 | 22 | 43 | 22 | 21 | 26 |
| 13 | 23 | 23 | 43 | 23 | 22 | 27 |
| 14 | 25 | 25 | 45 | 25 | 24 | 29 |
| 15 | 26 | 26 | 44 | 27 | 25 | 30 |
| 16 | 28 | 28 | 45 | 29 | 27 | 31 |
| 17 | 30 | 30 | 45 | 31 | 28 | 33 |
| 18 | 32 | 32 | 45 | 33 | 30 | 34 |
| 19 | 33 | 33 | 46 | 34 | 32 | 36 |
| 20 | 35 | 35 | 48 | 36 | 34 | 38 |
| 21 | 37 | 37 | 50 | 38 | 35 | 39 |
| 22 | 39 | 39 | 51 | 40 | 37 | 41 |
| 23 | 41 | 41 | 52 | 42 | 39 | 43 |
| 24 | 42 | 42 | 54 | 44 | 41 | 45 |
| 25 | 44 | 44 | 55 | 46 | 43 | 46 |
| 26 | 46 | 46 | 56 | 47 | 45 | 48 |
| 27 | 47 | 47 | 57 | 49 | 46 | 49 |
| 28 | 49 | 49 | 58 | 51 | 48 | 51 |
| 29 | 51 | 51 | 59 | 53 | 50 | 53 |
| 30 | 52 | 52 | 59 | 54 | 51 | 54 |
| 31 | 54 | 54 | 60 | 56 | 53 | 55 |
| 32 | 55 | 55 | 62 | 58 | 55 | 57 |
| 33 | 56 | 57 | 63 | 59 | 56 | 58 |
| 34 | 58 | 58 | 64 | 61 | 58 | 60 |

Individual and mean temperatures recorded on the unexposed surface of Doorset B

| Time Mins | T/C Number 7 Deg. C | T/C Number 8 Deg. C | T/C Number 9 Deg. C | T/C Number 10 Deg. C | T/C Number 11 Deg. C | Mean Temp Deg. C |
|--------------|------------------------------|------------------------------|------------------------------|-------------------------------|-------------------------------|------------------------|
| 0 | 18 | 19 | 19 | 19 | 19 | 19 |
| 2 | 18 | 19 | 19 | 19 | 19 | 19 |
| 4 | 19 | 19 | 19 | 19 | 19 | 19 |
| 6 | 18 | 19 | 19 | 19 | 19 | 19 |
| 8 | 18 | 19 | 19 | 19 | 19 | 19 |
| 10 | 18 | 19 | 19 | 19 | 19 | 19 |
| 12 | 19 | 20 | 20 | 19 | 19 | 19 |
| 14 | 19 | 20 | 20 | 20 | 20 | 20 |
| 16 | 21 | 21 | 21 | 20 | 20 | 21 |
| 18 | 22 | 22 | 22 | 22 | 21 | 22 |
| 20 | 24 | 24 | 23 | 23 | 22 | 23 |
| 22 | 26 | 25 | 25 | 25 | 24 | 25 |
| 24 | 28 | 27 | 26 | 27 | 25 | 27 |
| 26 | 31 | 29 | 28 | 29 | 27 | 29 |
| 28 | 33 | 31 | 30 | 31 | 30 | 31 |
| 30 | 35 | 34 | 33 | 34 | 32 | 34 |
| 32 | 38 | 36 | 35 | 36 | 34 | 36 |
| 34 | 40 | 39 | 38 | 39 | 37 | 39 |
| 36 | 43 | 42 | 41 | 42 | 40 | 42 |
| 38 | 45 | 45 | 44 | 44 | 43 | 44 |
| 40 | 48 | 47 | 47 | 47 | 45 | 47 |
| 42 | 51 | 51 | 50 | 50 | 48 | 50 |
| 44 | 54 | 54 | 53 | 52 | 51 | 53 |
| 46 | 57 | 57 | 56 | 55 | 54 | 56 |
| 48 | 60 | 61 | 59 | 57 | 58 | 59 |
| 50 | 63 | 64 | 62 | 60 | 61 | 62 |
| 52 | 65 | 67 | 65 | 63 | 64 | 65 |
| 54 | 68 | 69 | 68 | 66 | 67 | 68 |
| 56 | 70 | 72 | 71 | 68 | 69 | 70 |
| 58 | 73 | 75 | 74 | 70 | 72 | 73 |
| 60 | 75 | 77 | 76 | 73 | 75 | 75 |

**Individual temperatures recorded on the unexposed surface of Doorset A
 100 mm in from door leaf edge**

| Time Mins | T/C Number 12 Deg. C | T/C Number 13 Deg. C | T/C Number 14 Deg. C | T/C Number 15 Deg. C |
|--------------|-------------------------------|-------------------------------|-------------------------------|-------------------------------|
| 0 | 19 | 19 | 19 | 15 |
| 1 | 19 | 20 | 19 | 15 |
| 2 | 21 | 20 | 19 | 15 |
| 3 | 21 | 20 | 19 | 15 |
| 4 | 22 | 20 | 19 | 15 |
| 5 | 22 | 20 | 20 | 16 |
| 6 | 21 | 20 | 20 | 16 |
| 7 | 21 | 20 | 20 | 16 |
| 8 | 21 | 21 | 20 | 16 |
| 9 | 22 | 22 | 20 | 17 |
| 10 | 24 | 24 | 21 | 18 |
| 11 | 27 | 26 | 22 | 20 |
| 12 | 30 | 29 | 24 | 23 |
| 13 | 34 | 31 | 26 | 26 |
| 14 | 37 | 34 | 28 | 29 |
| 15 | 40 | 37 | 30 | 32 |
| 16 | 44 | 40 | 32 | 35 |
| 17 | 46 | 42 | 34 | 37 |
| 18 | 49 | 44 | 36 | 40 |
| 19 | 51 | 46 | 38 | 42 |
| 20 | 53 | 48 | 40 | 44 |
| 21 | 55 | 50 | 42 | 46 |
| 22 | 57 | 52 | 43 | 48 |
| 23 | 59 | 53 | 45 | 50 |
| 24 | 60 | 54 | 47 | 52 |
| 25 | 61 | 56 | 48 | 53 |
| 26 | 62 | 57 | 50 | 55 |
| 27 | 63 | 58 | 51 | 56 |
| 28 | 65 | 60 | 53 | 57 |
| 29 | 65 | 61 | 54 | 58 |
| 30 | 66 | 62 | 56 | 60 |
| 31 | 67 | 63 | 57 | 61 |
| 32 | 68 | 64 | 59 | 62 |
| 33 | 69 | 65 | 60 | 63 |
| 34 | 69 | 67 | 62 | 64 |

**Individual temperatures recorded on the unexposed surface of Doorset B
 100 mm in from door leaf edge**

| Time Mins | T/C Number 16 Deg. C | T/C Number 17 Deg. C | T/C Number 18 Deg. C | T/C Number 19 Deg. C |
|--------------|-------------------------------|-------------------------------|-------------------------------|-------------------------------|
| 0 | 16 | 16 | 16 | 16 |
| 2 | 17 | 16 | 16 | 16 |
| 4 | 19 | 16 | 18 | 16 |
| 6 | 19 | 17 | 18 | 16 |
| 8 | 18 | 17 | 17 | 16 |
| 10 | 18 | 17 | 17 | 16 |
| 12 | 18 | 18 | 18 | 16 |
| 14 | 20 | 19 | 19 | 17 |
| 16 | 23 | 22 | 22 | 17 |
| 18 | 26 | 25 | 25 | 18 |
| 20 | 29 | 29 | 28 | 19 |
| 22 | 32 | 32 | 31 | 21 |
| 24 | 35 | 36 | 35 | 22 |
| 26 | 38 | 39 | 38 | 24 |
| 28 | 41 | 42 | 41 | 26 |
| 30 | 43 | 45 | 44 | 29 |
| 32 | 46 | 47 | 47 | 31 |
| 34 | 48 | 50 | 49 | 34 |
| 36 | 50 | 52 | 52 | 37 |
| 38 | 52 | 55 | 54 | 40 |
| 40 | 54 | 57 | 56 | 43 |
| 42 | 56 | 59 | 58 | 46 |
| 44 | 58 | 61 | 60 | 50 |
| 46 | 60 | 64 | 62 | 53 |
| 48 | 63 | 67 | 64 | 57 |
| 50 | 65 | 65 | 66 | 60 |
| 52 | 67 | 68 | 68 | 63 |
| 54 | 70 | 72 | 70 | 66 |
| 56 | 72 | 80 | 72 | 69 |
| 58 | 75 | 105 | 74 | 72 |
| 60 | 80 | 105 | 76 | 74 |

Individual temperatures recorded on the unexposed surface of Door Frame A

| Time Mins | T/C Number 20 Deg. C | T/C Number 21 Deg. C | T/C Number 22 Deg. C | T/C Number 23 Deg. C |
|--------------|-------------------------------|-------------------------------|-------------------------------|-------------------------------|
| 0 | 16 | 16 | 18 | 18 |
| 1 | 16 | 16 | 18 | 17 |
| 2 | 16 | 21 | 24 | 18 |
| 3 | 16 | 25 | 33 | 18 |
| 4 | 16 | 36 | 44 | 18 |
| 5 | 16 | 43 | 50 | 18 |
| 6 | 16 | 46 | 53 | 18 |
| 7 | 16 | 46 | 51 | 18 |
| 8 | 16 | 46 | 49 | 18 |
| 9 | 16 | 47 | 44 | 18 |
| 10 | 16 | 44 | 39 | 18 |
| 11 | 16 | 42 | 35 | 18 |
| 12 | 16 | 40 | 33 | 18 |
| 13 | 17 | 39 | 31 | 18 |
| 14 | 17 | 40 | 31 | 19 |
| 15 | 17 | 42 | 30 | 19 |
| 16 | 18 | 44 | 30 | 20 |
| 17 | 18 | 47 | 30 | 20 |
| 18 | 19 | 47 | 31 | 20 |
| 19 | 19 | 50 | 31 | 21 |
| 20 | 20 | 52 | 32 | 22 |
| 21 | 20 | 53 | 33 | 22 |
| 22 | 21 | 53 | 33 | 23 |
| 23 | 22 | 52 | 34 | 24 |
| 24 | 23 | 51 | 35 | 25 |
| 25 | 24 | 50 | 35 | 25 |
| 26 | 25 | 51 | 36 | 26 |
| 27 | 26 | 52 | 36 | 27 |
| 28 | 26 | 53 | 37 | 28 |
| 29 | 27 | 54 | 38 | 28 |
| 30 | 28 | 55 | 39 | 29 |
| 31 | 30 | 57 | 40 | 30 |
| 32 | 31 | 58 | 41 | 31 |
| 33 | 32 | 60 | 42 | 32 |
| 34 | 33 | 62 | 43 | 33 |

Individual temperatures recorded on the unexposed surface of Door Frame B

| Time Mins | T/C Number 24 Deg. C | T/C Number 25 Deg. C | T/C Number 26 Deg. C | T/C Number 27 Deg. C |
|--------------|-------------------------------|-------------------------------|-------------------------------|-------------------------------|
| 0 | 18 | 18 | 18 | 18 |
| 2 | 18 | 23 | 21 | 18 |
| 4 | 18 | 28 | 30 | 18 |
| 6 | 18 | 26 | 39 | 18 |
| 8 | 18 | 24 | 40 | 18 |
| 10 | 18 | 23 | 44 | 18 |
| 12 | 18 | 23 | 44 | 18 |
| 14 | 18 | 23 | 42 | 18 |
| 16 | 18 | 23 | 40 | 18 |
| 18 | 19 | 23 | 37 | 18 |
| 20 | 19 | 24 | 34 | 19 |
| 22 | 19 | 25 | 33 | 19 |
| 24 | 20 | 25 | 32 | 19 |
| 26 | 20 | 26 | 32 | 19 |
| 28 | 21 | 27 | 32 | 20 |
| 30 | 22 | 27 | 32 | 20 |
| 32 | 23 | 28 | 32 | 21 |
| 34 | 24 | 29 | 33 | 21 |
| 36 | 26 | 30 | 34 | 22 |
| 38 | 27 | 31 | 35 | 22 |
| 40 | 28 | 32 | 36 | 23 |
| 42 | 30 | 33 | 38 | 24 |
| 44 | 31 | 34 | 39 | 24 |
| 46 | 32 | 35 | 41 | 25 |
| 48 | 34 | 37 | 57 | 26 |
| 50 | 35 | 39 | 52 | 27 |
| 52 | 36 | 43 | 54 | 28 |
| 54 | 37 | 45 | 57 | 29 |
| 56 | 39 | 50 | 68 | 30 |
| 58 | 40 | 63 | 67 | 31 |
| 60 | 42 | 78 | 120 | 32 |

Horizontal deflections of the door leaves and door frames during the test

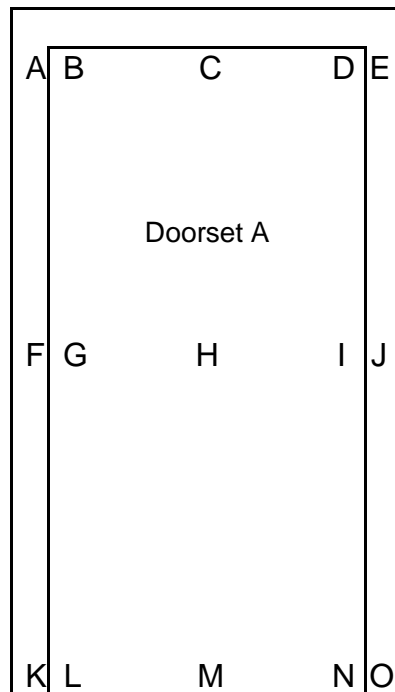

| Doorset A | | | | | | | | | | | | | | | |
|------------------|---|---|----|----|----|----|----|-----|----|----|----|----|---|----|---|
| Deflections – mm | | | | | | | | | | | | | | | |
| TIME mins | A | B | C | D | E | F | G | H | I | J | K | L | M | N | O |
| 0 | 0 | 0 | 0 | 0 | 0 | 0 | 0 | 0 | 0 | 0 | 0 | 0 | 0 | 0 | 0 |
| 5 | 1 | 3 | -2 | -1 | -1 | 1 | -1 | -3 | -2 | 0 | -1 | 2 | 0 | 0 | 1 |
| 10 | 1 | 5 | -2 | -1 | 1 | -1 | -1 | -5 | -3 | 1 | 1 | 3 | 0 | 0 | 0 |
| 15 | 2 | 6 | -2 | 0 | 0 | -2 | -1 | -8 | -2 | 0 | 2 | 6 | 5 | 12 | 1 |
| 20 | 1 | 8 | -2 | 4 | 0 | -2 | -4 | -12 | -1 | 1 | 2 | 10 | 7 | 17 | 3 |
| 25 | 2 | 8 | -2 | 6 | 1 | -3 | -3 | -14 | -1 | -1 | 0 | 10 | 8 | 19 | 2 |
| 30 | 3 | 7 | -2 | 4 | 0 | -3 | -5 | -18 | -2 | -1 | 0 | 12 | 8 | 22 | 4 |

A positive value indicate a deflection towards the heating conditions of the test

Horizontal deflections of the door leaves and door frames during the test (continued)

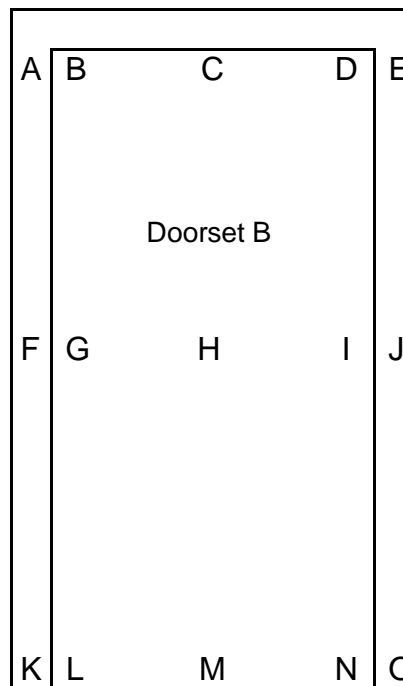

| Doorset B | | | | | | | | | | | | | | | |
|------------------|---|---|---|---|---|---|----|-----|----|----|---|---|----|---|---|
| Deflections – mm | | | | | | | | | | | | | | | |
| TIME mins | A | B | C | D | E | F | G | H | I | J | K | L | M | N | O |
| 0 | 0 | 0 | 0 | 0 | 0 | 0 | 0 | 0 | 0 | 0 | 0 | 0 | 0 | 0 | 0 |
| 10 | 1 | 1 | 2 | 2 | 1 | 0 | -3 | -3 | -1 | 0 | 4 | 0 | 0 | 2 | 1 |
| 20 | 2 | 3 | 0 | 2 | 2 | 0 | -3 | -3 | -3 | -1 | 3 | 3 | 4 | 5 | 0 |
| 30 | 3 | 2 | 2 | 4 | 1 | 0 | -3 | -7 | -4 | -3 | 4 | 4 | 2 | 5 | 0 |
| 40 | 2 | 5 | 1 | 5 | 0 | 0 | -3 | -15 | -5 | -3 | 5 | 6 | 1 | 5 | 2 |
| 50 | 1 | 7 | * | * | * | 4 | -2 | -12 | -5 | -2 | 3 | 5 | -3 | 7 | 2 |

A positive value indicate a deflection towards the heating conditions of the test
 *laser reading malfunction

Graph showing mean furnace temperature, together with the temperature/time relationship specified in the Standard

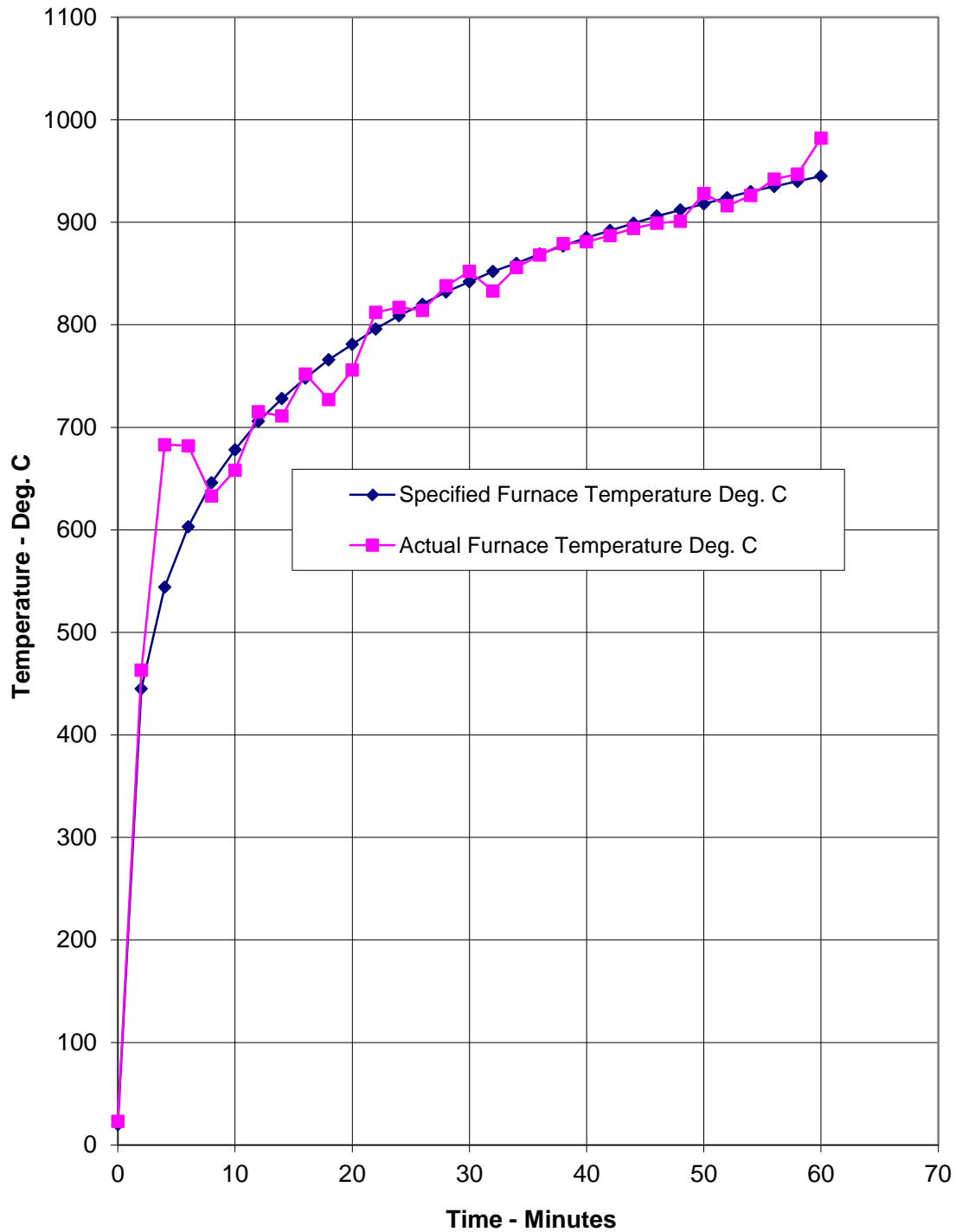

Graph showing mean temperatures recorded on the unexposed surface of Doorset A

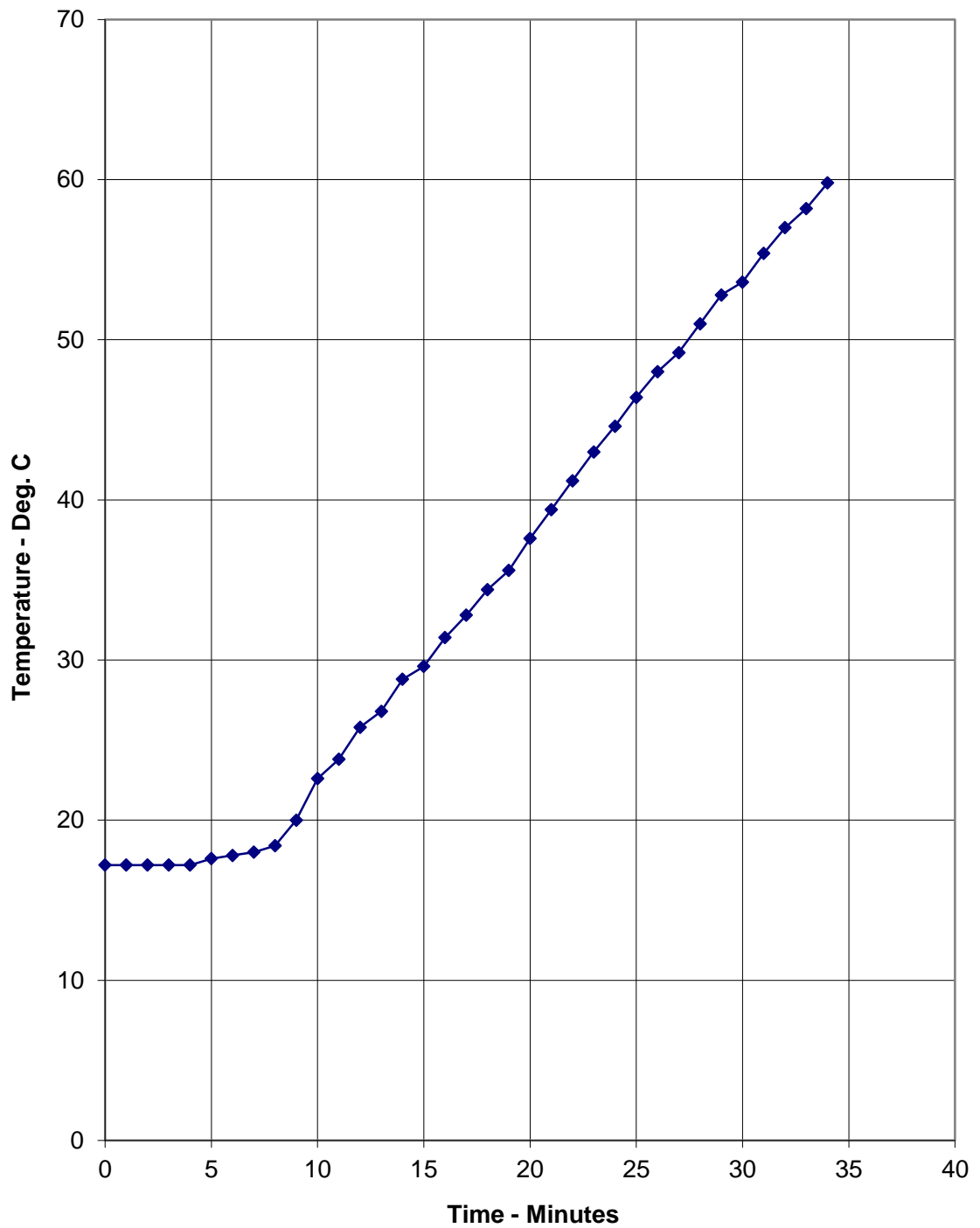

Graph showing mean temperatures recorded on the unexposed surface of Doorset B

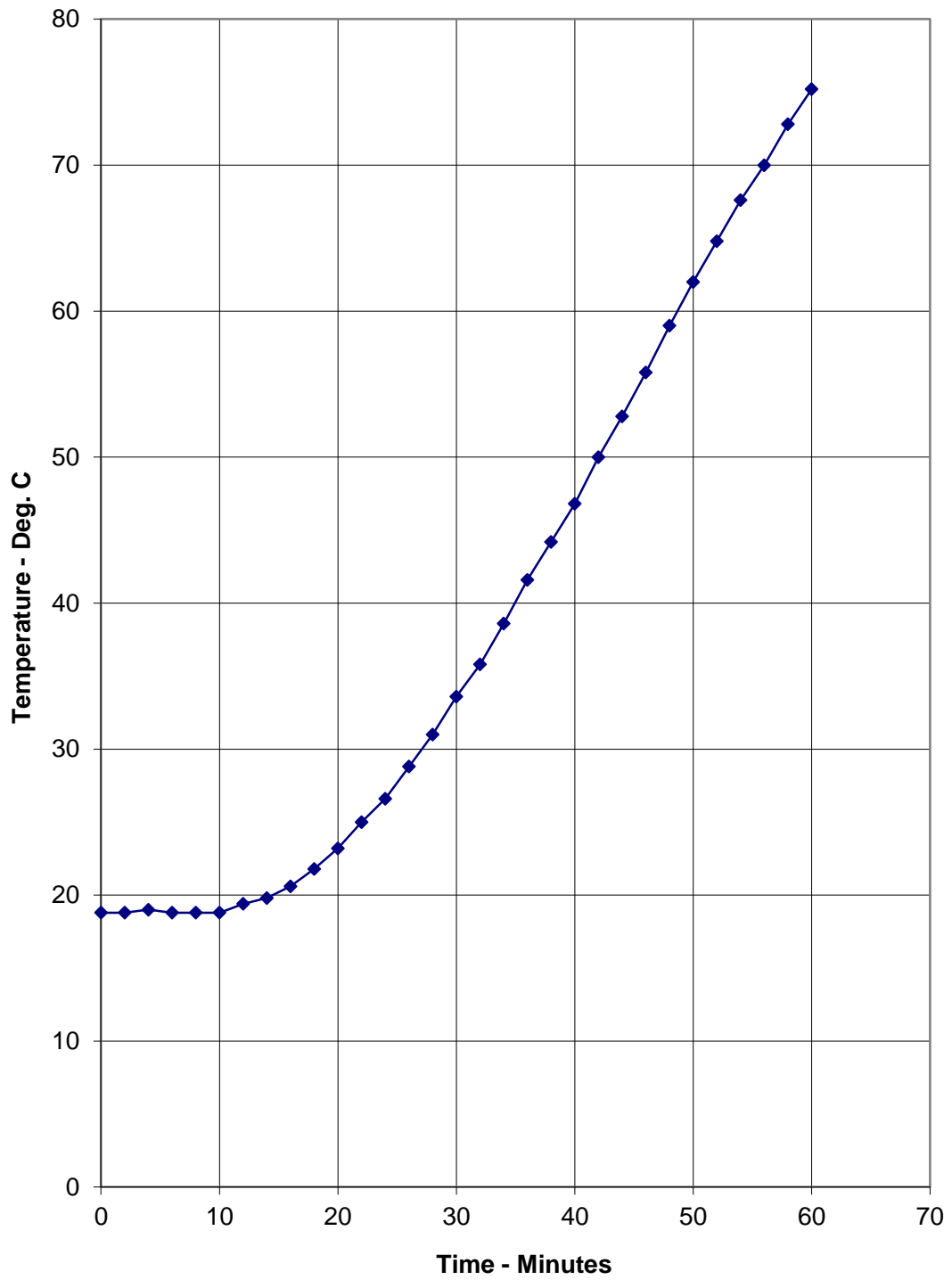

Graph showing recorded furnace pressure at the head of the Doorsets

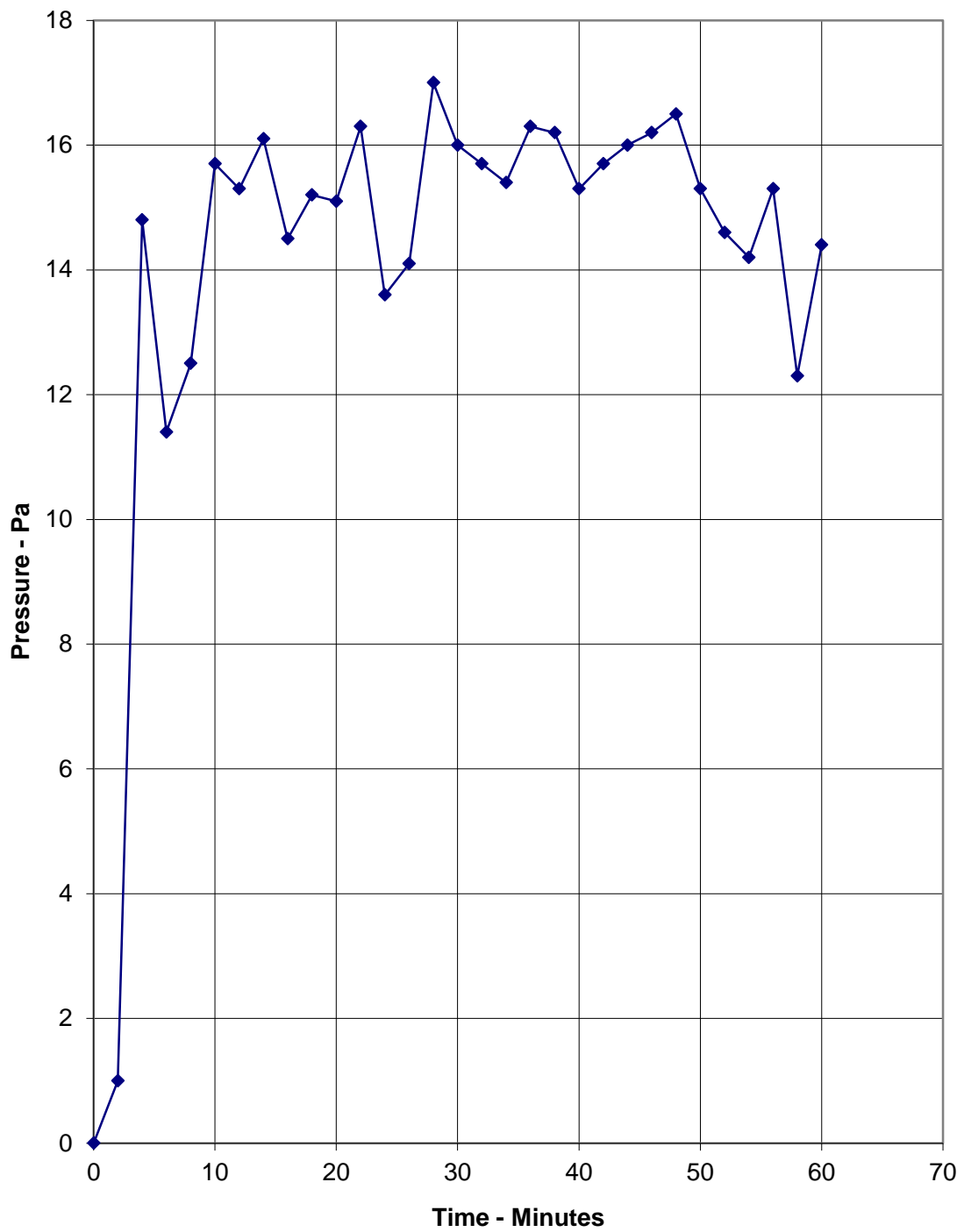

Performance Criteria and Test Results

Integrity

It is required that the specimen retain its separating function, without either causing ignition of a cotton pad when applied, or permitting the penetration of a gap gauge as specified in BS EN 1634-1: 2014, or resulting in sustained flaming on the unexposed surface. **These requirements were satisfied for the periods shown below:**

| | Doorset A | Doorset B |
|--------------------------|------------|-------------|
| Sustained flaming | 34 minutes | 46 minutes |
| Gap gauge | 34 minutes | 60 minutes* |
| Cotton pad | 34 minutes | 46 minutes |

Insulation

The mean temperature rise of the unexposed surface shall not be greater than 140°C and that the maximum temperature rise shall not be greater than 180°C (except on the door frame, where the maximum temperature rise shall not exceed 360°C). Insulation failure also occurs simultaneously with integrity failure as specified in BS EN 1634-1: 2014. **These requirements were satisfied for the periods shown below:**

| | |
|------------|-------------|
| 34 minutes | 46 minutes* |
|------------|-------------|

* The test duration. The test was discontinued after a period of 60 minutes.

Ongoing Implications

Limitations

This report details the method of construction, the test conditions and the results obtained when the specific element of construction described herein was tested following the procedure outlined in BS EN 1363-1: 2012 and where appropriate BS EN 1363-2: 1999. Any significant deviation with respect to size, constructional details, loads, stresses, edge or end conditions other than those allowed under the field of direct application in the relevant test method is not covered by this report. Annex A of BS EN 1363-1: 2012 provides guidance information on the application of fire resistance tests and the interpretation of test data.

Because of the nature of fire resistance testing and the consequent difficulty in quantifying the uncertainty of measurement of fire resistance, it is not possible to provide a stated degree of accuracy of the result.

This test report is additional to that issued as WF Test Report No. 345074 and dated 13th January 2015. The original test report remains valid and is not replaced by this additional test report. The product referred to in the original report and this additional test report has not been re-tested, this report does not involve technical change or technical review of the original test report.

Conclusions

Evaluation against objective

Two single-acting single-leaf doorsets incorporating various items of hardware have been subjected to a fire resistance test in accordance with BS EN 1634-1: 2014, Fire resistance tests for door and shutter assemblies, BS EN 1363-1: 2012 General requirements and BS EN 1363-2: 1999, Alternative and additional procedures.

The evaluation of the doorsets against the requirements of BS EN 1634-1: 2014 showed that each doorset satisfied the requirements for the following periods.

| Test Results: | | Doorset A | Doorset B |
|-----------------------|-------------------|------------|-------------|
| Integrity performance | Sustained flaming | 34 minutes | 46 minutes |
| | Gap gauge | 34 minutes | 60 minutes* |
| | Cotton Pad | 34 minutes | 46 minutes |
| Insulation | Doorset | 34 minutes | 46 minutes |

* The test duration. The test was discontinued after a period of 60 minutes.