

Nu Mail Letterplate



Features

- **Midrail and panel letterplate options to suit doors 20mm-80mm thick**
Suits a range of door thickness
- **Fully colour matched metal letterplate**
Quality and durability you can see and feel
- **Anti-snap flap opens to 180° with fully sprung return**
Easier to operate, no broken flaps, even with Sunday papers
- **12" letterplate with a 10" aperture**
Meets Royal Mail standards, will easily take A4 size post
- **Fully weather Sealed (with rubber gasket)***
No draft, no rain water
- **Secure through fixing ensures letterplate can only be removed from the inside of the house**
Prevents burglars gaining access to the cylinder internally
- **Can be through fixed or face fixed**
Flexible according to fabricator preference
- **Outstanding acoustic insulation***
Perfect for flats, or houses near busy roads
- **Supplied with screw fixings**
Everything needed for installation included
- **Secured by Design**
Additional peace of mind

*For best acoustic and weather performance we recommend installing the product with a rubber gasket

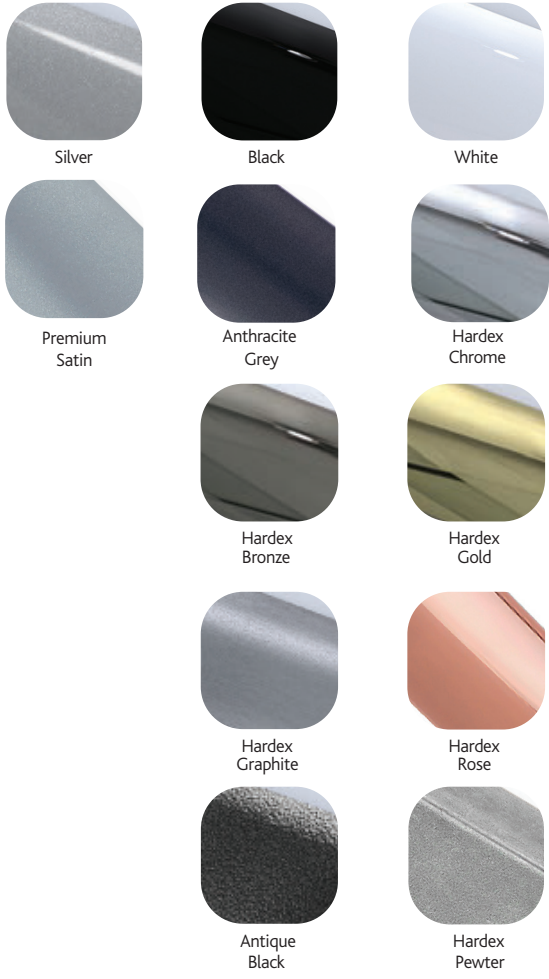

Nu Mail Letterplate

Ordering Details

Product

Nu Mail Letterplate

	Panel 68 (20-40)		Midrail 76 (40-80)	
	Part No.	Part No.	Part No.	Part No.
Hardex Chrome	3C301	3C101	3C201	3C001
Hardex Bronze	3C303	3C103	3C203	3C003
Hardex Gold	3C305	3C105	3C205	3C005
Hardex Graphite	3C311	3C111	3C211	3C018
Hardex Pewter	-	-	-	3C011
Hardex Rose	-	-	-	DLPNMHRMI76
Antique Black	3C306	3C106	3C206	3C006
Anthracite Grey	-	3C112	-	-
White	3C300	3C100	3C200	3C000
Black	3C308	3C108	3C208	3C008
Silver	3C309	-	3C209	3C009
Premium Satin	DLPNMPSA68	DLPNMPSMI68	DLPNMPSA76	DLPNMPSMI76

*Easy Fit Rubber Drip Gasket 9B000

Technical Information

Corrosion resistance

Meets the requirements of BS EN 1670:2007 Grade 5 (480 hours)

Operation

Flap cycle tested to 30,000 cycles

Conforms to the requirements of BS EN 13724: 2002

Performance

Tested as part of a complete door set that successfully achieved PAS 24. 30 minute fire test to BS 476: Part 20/22: 1987

Screws

Midrail version includes 2 x M5 x 45mm machine screws, 2 x M5 x 63mm machine screw, 2 x M5 x 74mm machine screws and 2 screw guides

Panel version includes 2 x M5 x 28mm machine screws and 2 screw guides

Material Specification

Frame and Flap: High quality Zinc

Coatings: Hardex Chrome, Hardex Bronze, Hardex Gold, Hardex Graphite, Hardex Pewter, Hardex Rose, Antique Black, Anthracite Grey, Premium Satin, White, Black and Silver.

Maintenance

For continued protection of the quality finish and appearance, we advise routine cleaning of all our external hardware. We recommend wiping it with a clean cloth soaked in warm water and mild detergent every month. Please refrain from using heavy-duty cleaners, containing Chlorine or Potassium. Moving parts should also be lightly lubricated using a light non-acidic mineral oil (e.g. "3 in 1") at least twice per year. The product may need to be adjusted and fixings tightened to ensure a satisfactory operation. This procedure is particularly essential if products are used within a 25-mile radius of coastal areas or close proximity to building sites or large industrial areas, where more frequent cleaning may be required to prevent the accumulation of corrosive contaminants.

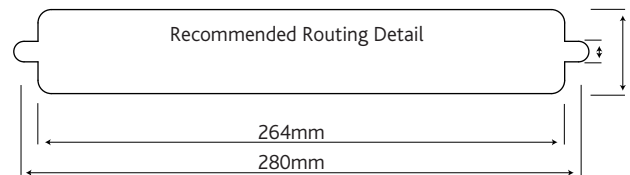
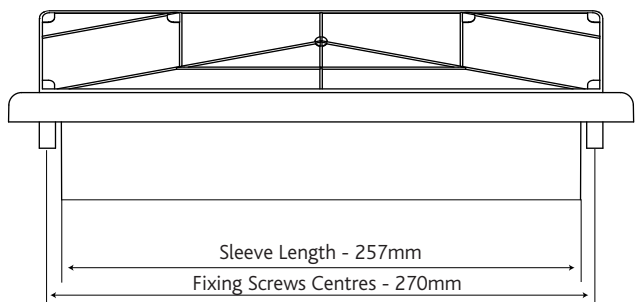
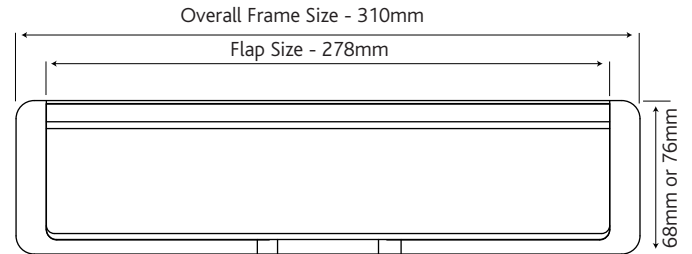

Panel Sleeve Set
20mm-40mm

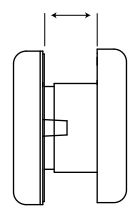

Midrail Sleeve Set
40mm-80mm

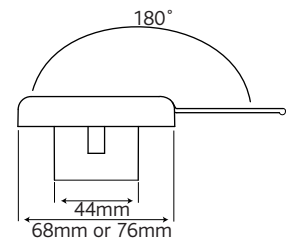
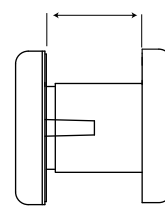

Fixing Screws Provided

All dimensions are in mm and are nominal.
Fab&Fix reserves the right to change specification without notice.
It is the responsibility of the door manufacturer to ensure that the finished product meets any required safety and performance specification.

Packaging

Nu Mail Letterplate

Individually boxed with fixings and care instructions.
15 letterplates in an outer box.